

## Raised Access Flooring TecCrete: 1-1/8" and 1-1/2" Panel

- **Installation Manual**
- **Maintenance Manual**
- **Technical Manual**
- **Owner's Manual**

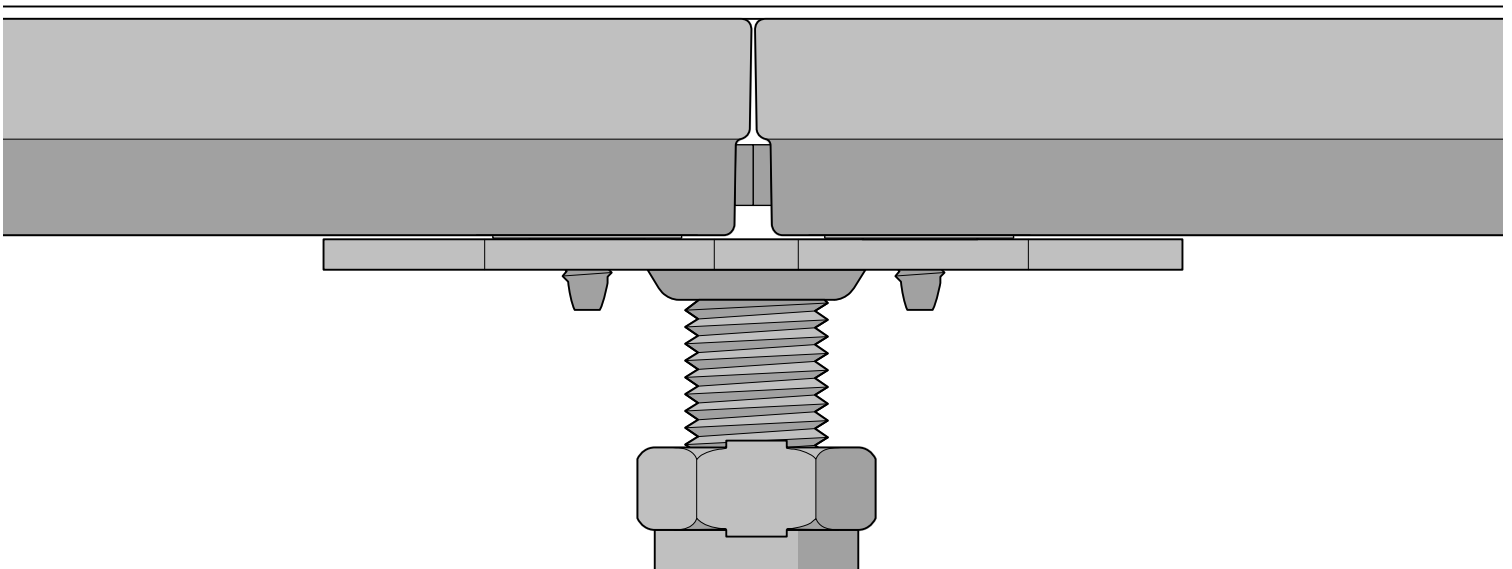

## COMMON COMPONENTS

Access Floor Panel

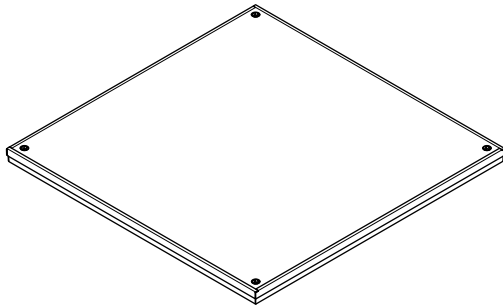

Perforated Panel

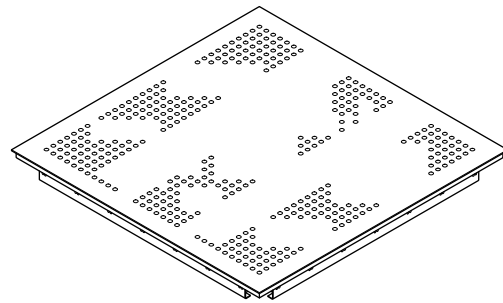

Field Head

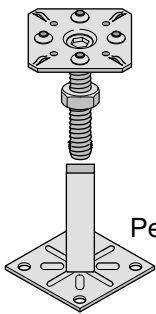

Perimeter Head

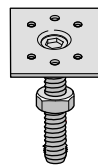

Low Profile Field Head

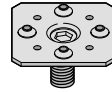

Low Profile Perimeter Head



Pedestal Base

Low Profile Pedestal Base

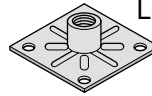

Stringers

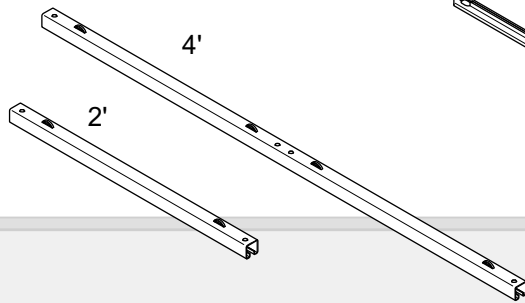

Gasket

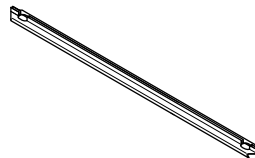

Ramp Swivel Head

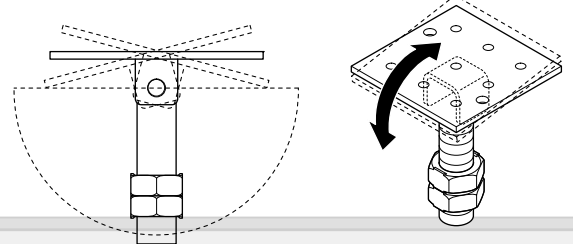

Ramp

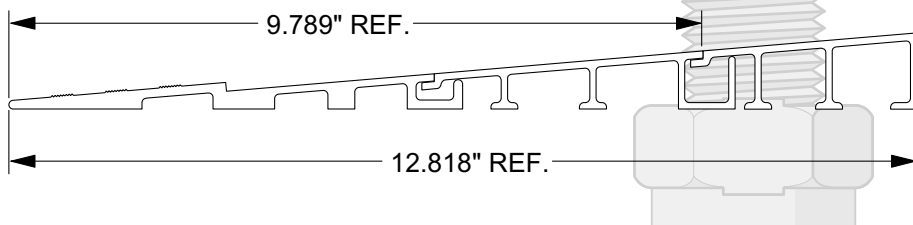

## CONTENTS

	Glossary of Terms.....	3
1	System Characteristics.....	4
2	List of Tools.....	6
3	Storage of Materials.....	6
4	Getting Started.....	7
5	Screws and Fasteners.....	17
6	Subfloors.....	17
7	Special Instructions.....	19
8	Specific Understructure Instructions.....	21
9	Lateral Braces/Cutouts.....	23
10	Grounding of the Access Floor System.....	23
11	Owners Manual.....	36
12	Warranty Procedure.....	27

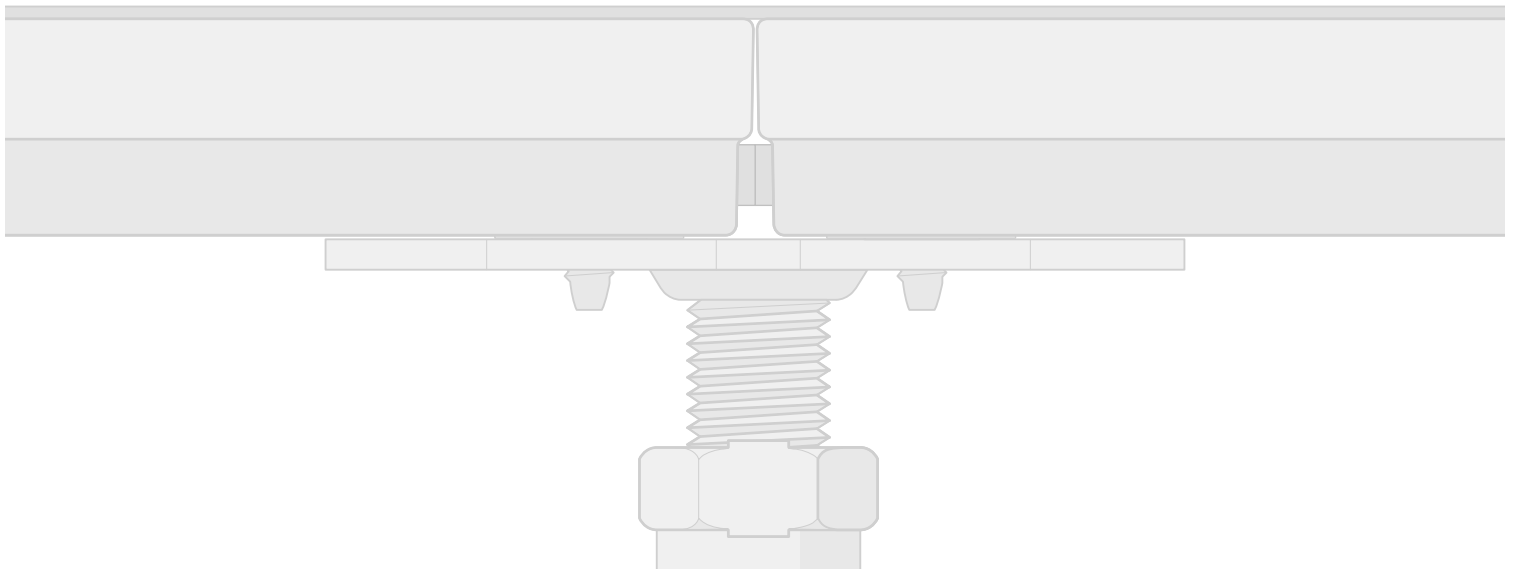

## GLOSSARY OF TERMS

Adjusting Nut	Nut used in the pedestal assembly to compensate for subfloor variation.
A/F	Access Floor System including panels, pedestals, and accessories.
B/M	Bill of Material.
C/L	Center Line.
Click	1/4 turn of the adjusting nut, approximately 0.014".
Cuts	Panels which have been altered by cutting to fit a specific location.
Dry Line	A string used as a temporary reference line which establishes the portion of the initial row of panels in the access floor installation.
ELL	Section of access floor laid along perpendicular dry lines forming an L Shape, normally three of four panels wide.
FFH	Finished Floor Height The dimension from the top of the access floor panel to the subfloor.
Field	The main open area of the floor where full panels are installed.
Free Edge	The point in the installation where panels are being installed on fresh pedestals.
Grid Line	Lines formed by the center line of the joint between the access floor panels.
Intermediate Pedestals	Pedestals whose elevation is set by using the leveling bar.
Laser	An electronic transit that projects a laser beam to establish elevations.
Leveling Bar	A tubular or extruded straight edge with permanent center line marks at two-foot increments that are used to level and roughly locate intermediate pedestals. Dimensions are at minimum 0.75" x 2.5" x 0.080" wall thickness by 10 feet long. Bar is usually constructed from aluminum to minimize the weight of the leveling bar.
Mechanical Anchor	A fastening device used to attach pedestals or other accessories to the concrete slab instead of adhesive. Typically they require a hole to be drilled in the concrete and a nut placed on the bolt to secure the pedestal and used in seismic or special conditions.
Plumb Pedestal	90 degrees from the horizontal plane.
Base	An assembly of the pedestal tube and base plate.
Pedestal	Assembly of pedestal head, base plate, pedestal tube, adjusting nut, and threaded stud used to support the panels at the required finished floor height.
Primary Pedestals	Pedestals whose elevation is set by using laser or transit and act as supports for the leveling bar.
Rocker	A panel that rocks up and down diagonally when installed.
Shoot In	Establish control height reference points in a subfloor area using a transit or laser.
Start Point	A specific location on the subfloor designated as the installation starting point. Note that this point may not always be in the corner of the room as shown in the illustrations.
Stringer	Lateral member used to connect the pedestals to each other and to support vertical loads. They may be one or two panels in length.
Square	To establish lines which are perpendicular to each other.
Transit.	Builders optical leveling device used for establishing grade levels for floors, ceilings, etc.
Through Bolt	Used to fasten floor track or other components to a raised floor panel. Hole is drilled through panel and device is fastened to the panel using a bolt, washer and nut assembly.

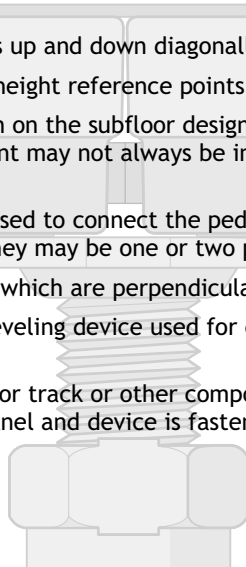

## 1 SYSTEM CHARACTERISTIC GUIDE

The following installation guide is provided to establish a quick review of the two different panel and understructure systems. The benefits of the different systems are defined and the applications where they would most likely be used.

### 1.1 Panel Selection

- A. **TecCrete™ 1 1/8" & 1 1/2" - Concrete Panel - General Office & Computer Room**  
 This patented panel can be used bare or covered in carpet, laminate, vinyl, rubber or other finishes. It is the perfect solution for general office, schools, computer rooms, museums and casinos. Integral corner-lock inserts and non-combustible construction provide the end user with a durable, quiet, and trouble free installation. The nominal bare panel is sized 24" square, the 1.125" thick panel weighs 42 pounds and the 1.5" thick panel weighs 55 pounds. Available in standard finished floor heights of 3" to 30". For higher finished floor heights contact the factory.

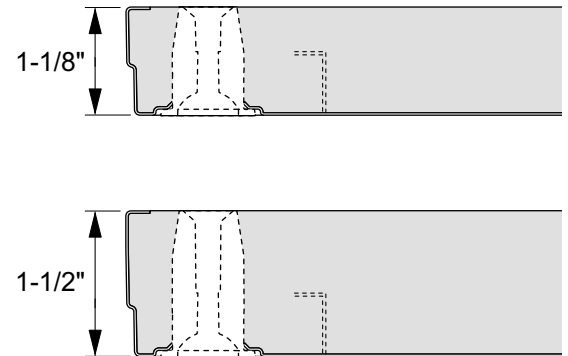

### 1.2 Understructure Selection

- A. **Corner-Lock**  
 This system is used in office areas where quietness, firmness underfoot, and complete access are required. The panels are fastened to the pedestal head using a screw which completely interconnects the access floor system laterally and vertically. Once the fasteners are removed and the panels lifted, access to the plenum area is completely unobstructed.  
 The corner-lock screws are meant to be stabilizers for the panels and pedestals. Do not use them to speed pedestal head adjustment. Install the floor panels as if the job was a free standing system and then tighten the panels down. This will help prevent stripped screws and broken panel corners.

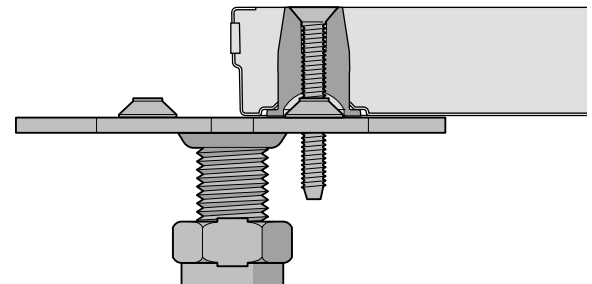

- B. **Corner-Lock with Bolted Stringers**  
 The panels and stringers are attached to the pedestals with fasteners. This system provides the highest lateral and vertical load carrying capacity available generating the greatest system stability. Access to the under floor area is more difficult due to the number of fasteners used. Typical applications for this system would be seismic zones, factory floors, casinos, and critical test facilities.

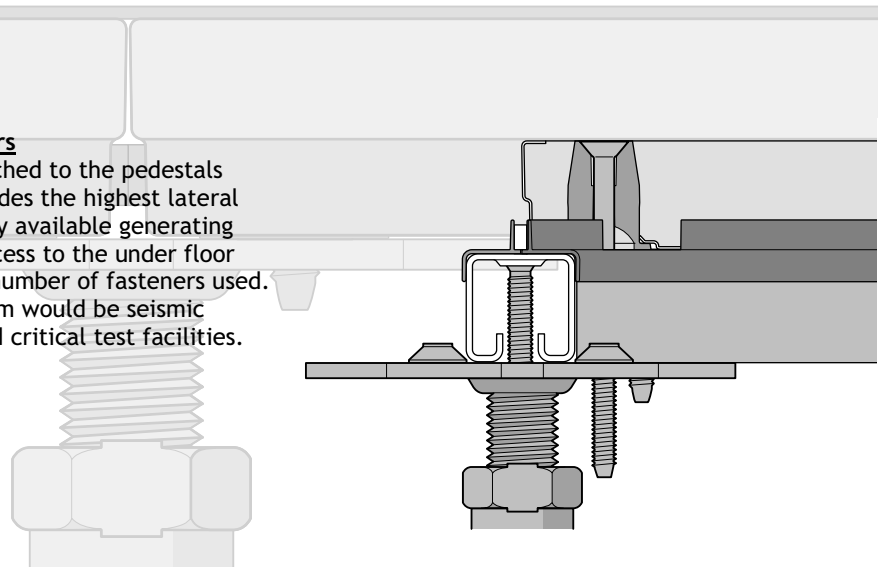

C. **Load Bearing Bolted Stringer**

The load bearing bolted stringer system uses a fastener to rigidly attach the stringer to the pedestal head. The panels are free to be readily removed with a standard lifting device while the stringers remain attached to the pedestal to maintain the module spacing and to stabilize the pedestals for lateral movement. These systems are used where system strength, access, rigidity and electrical conductivity are required. Typical applications are high-density offices, computer room areas and spaces over 18" finished floor height.

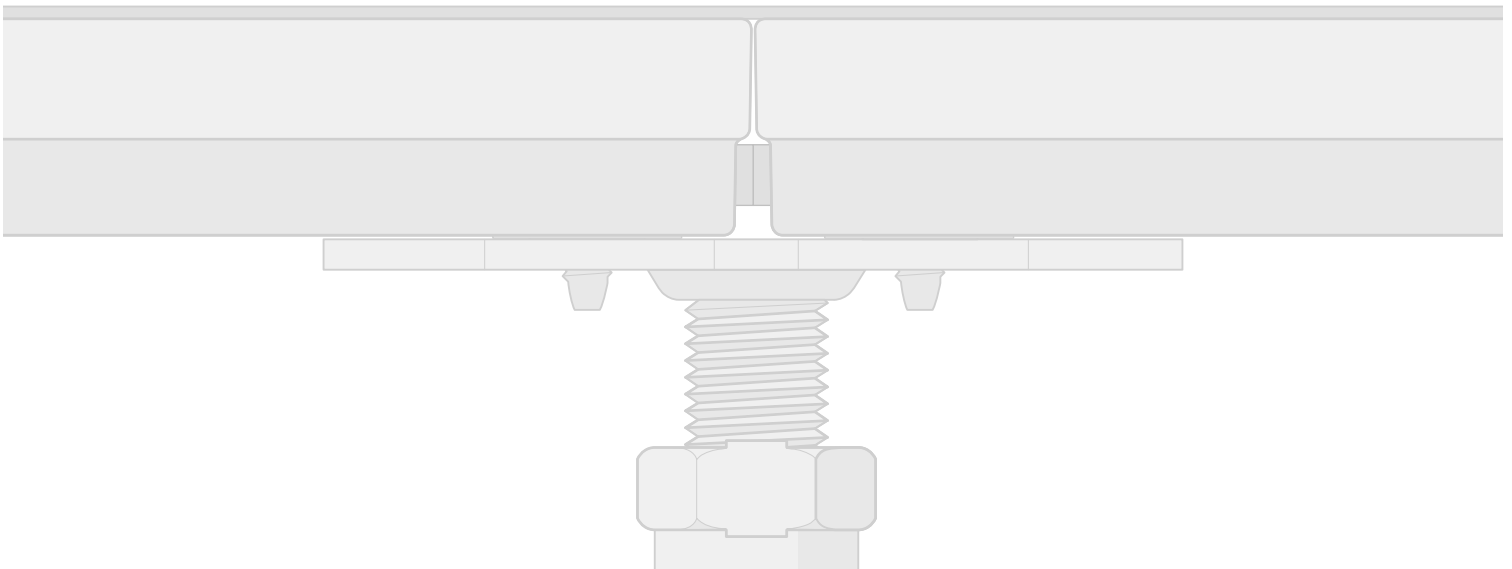
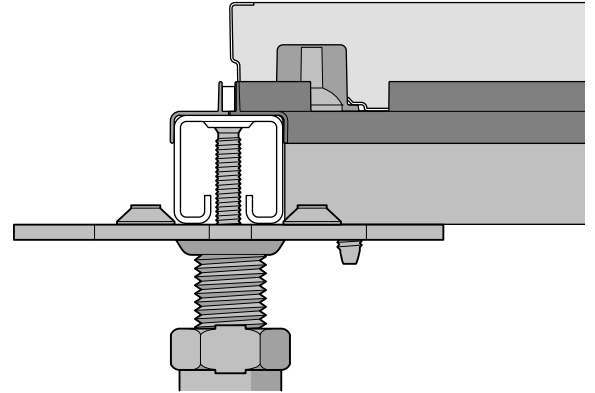

## 2 LIST OF TOOLS

The list of tools shown here is not intended to be all inclusive or limiting for the installer. Specific manufacturers have been cited as an aid to sourcing equipment which others have found to be effective. Similar equipment can be obtained from other sources.

### Small Projects

- Chalk line, chalk, and 2 dry lines
- 24" level (accurate & sensitive)
- Leveling bar
- Extension cords (50 & 100)
- Hacksaw w/12- or 14-tooth blades
- 12" adjustable wrench
- 10" adjustable pliers and 8" locking pliers
- Pop rivet gun w/1/8" rivets
- Hole saws, core bits, 1/2" hammer drill
- Tape measures (20 & 100)
- Heavy duty orbital bayonet saw w/14-tooth diamond tip blade
- Set of screw drivers
- Aviation tin snips
- Tripod and optical level or laser
- Metal miter box
- 20oz. claw hammer
- Wood and cold chisels
- Awl
- Metal file
- Vacuum cleaner
- 20"- 22" pallet jack

- 3/8" reversible drill w/drill set, counter sink bit, 1/4" flat head bit, hole saw, and core bits
- Double cup lifter
- Carpet lifter
- Safety glasses & gloves

### Large Projects

- 14" band saw and blades
- Diamond tipped saw & blades
- Shot pin gun and shot pins
- 1/2" drill w/adjustable torque limiting, screw gun, battery or electric power, charger (if needed), carbide tip replacement bits (#2P and #3P).
- Set of carbide or diamond tip bits
- 1/2" minimum plywood overlay material
- Calculator
- Job box

## 3 STORAGE OF MATERIALS

Access flooring materials are interior products intended for use in an office environment. The materials are for interior use and should not be subjected to outside conditions. The installation of an access floor requires a thorough understanding and control of the building space receiving the access floor materials.

Haworth panel systems must be handled as interior materials.

### 3.1 Proper Conditions for On-Site Storage and Installation of Access Floors

- The customer must provide a dry accessible area to receive and unload material with a free path to elevators, hoists, and/or the area receiving the access floor.
- Prior to the start of installation, a secure and dry storage space closed to the weather must be made available for the access floor materials, with recommended environment at 40 degrees F to 90 degrees F, and approximately 35% to 70% relative humidity.
- The installation area must be closed to the weather, with the recommended environment at 40 degrees F to 90 degrees F, and approximately 35% to 70% relative humidity, 24 hours a day during and after installation.
- The subfloor surface must be free of moisture, dust, dirt, and other debris. After installation, the access floor must be maintained in the same manner.
- It is recommended to acclimatize the materials to the anticipated interior storage usage temperature for 24 hours prior to the start of installation and maintain this temperature throughout the installation process. This will minimize any problems associated with panel size changes due to wide variations in temperature and humidity.

## 4 GETTING STARTED

All Haworth TecCrete systems use the same basic method to start the installation process. The procedures outlined below, planning, and attention to detail will allow you to install a quality product for your customer. Other methods can be used if proper attention to the installation details are observed. The installation process will be much easier to manage if the installation area is undisturbed during the first two days of assembly. An unlevelled, out of square start may not be correctable without complete reassembly.

### 4.1 Starting the Installation

#### 1. Free of Trades

The installation area should be free from other trades during the installation. This is especially true during the initial squaring and laying of the first few rows of panels. There should not be any traffic on freshly laid panels as this can cause the module lines to drift, the installation squareness to be lost, and the pedestals to shift resulting in rocking panels. A minimum 48 hour curing period is required for the installation to hold position at the minimum recommended installation temperatures. A minimum of four panel widths of flooring is required to fix the location and squareness of the system.

#### 2. Site Conditions

As soon as possible after the Award of Contract, visit the job site to verify the Plan Drawings, look at the material delivery and storage situations, check the progress and schedule of the job and evaluate the condition of the subfloor. An early visit will allow you to correct any material quantities, pedestal height, or scheduling problems which you may find. If there is more than four weeks to the installation time of the access floor, visit the job site as often as practical to stay current with the job progress. The environmental conditions should follow those outlined in Storage of Materials. Any deviations should be corrected before commencing installation. Verify that the concrete sealer (if used) is compatible with the pedestal adhesive. This is especially true if the specification dictate specific pedestal turnover performances. See the Sealer Section for testing instructions. If any deviations from the Plans are noted, you will need to discuss these with the General Contractor and determine how to address them.

#### 3. Material Delivery

Verify how to get material from the truck to the work area. Answering the following questions will help you have the right manpower and equipment on hand to move the material into the work area.

- Is there a loading dock?
- Can a truck get to it from the street?
- Can you deliver materials inside the building?
- Do you need any ramps to get over obstructions?
- Are there elevators and what is the schedule for lifting your material?
- Can you use a hoist to bring material into the area?
- How must the materials be distributed in the installation area?

Once the truck arrives it is your responsibility to check the Bill of Lading to determine if it agrees with what materials are on the truck. Any differences or damaged materials must be noted and forwarded to the trucking company for corrective action. Do this immediately.

After verifying the material counts disperse the material to the work area. This will also help minimize the labor for moving material when installing panels. Do not stack all the material in one location. Access floor materials can weight 300 pounds per square foot when skids of panels are stacked next to each other. Most above ground slabs are rated at 50 - 150 pounds per square foot. Do not place more than 25 - 30 skids per bay of the building.

#### 4. Pre-Construction Meeting with Trades

Any successful construction project requires cooperation and understanding from everyone working on the project. Access floors are no different. In fact most trades may not be familiar with the access floor installation process or what is important to enable you to install the product quickly and without problems. If possible, you should meet with the other trades to discuss the access floor installation process and how to work with their needs so you both may have a fast and profitable installation with minimum interference.

You should provide the following:

- Start points for each area.
- Layout chalk lines for pedestal runs, or spray paint a 10 x 10 grid of approximate pedestal locations. This will enable the other trades to stay clear of the pedestal locations.

- Since access floors are an interior finish, it is advisable to have any overhead work completed before the access floor installation begins. Damage may result to the access floor panels if the overhead work is performed on top of the access floor.
- Inform all trades of the rolling load and concentrated load rating of the systems being installed. Ask them about any lifts the crews may be using. Battery powered lifts have very high rolling loads. Make sure the wheel loads are in compliance with the floor systems capabilities. If there is no alternative equipment, a 1/2" minimum plywood overlay should be used.
- Advise that lifts or scaffolds should not be operated at the edge of the installation at any time.
- Inform the carpet tile installer of the potential for squeaks if excess adhesive is applied between the panels and that it is imperative that the adhesive is dry before the carpet tiles are placed to prevent oxidation of the galvanized surfaces.
- Inform all trades of any fasteners to attach the stringers or panels, the torque limits of the fasteners, and the proper bit sizes.
- Make sure enough panel lifters are available so panels may be placed and removed properly and inform them of the proper method of lifting and replacing the panels.

## 5. Determining the Start Point

**Figure 1** shows a typical starting layout in the corner of a room situated along the longest wall. This point may not be desirable due to design requirements to have the module lines match the column lines, the ceiling grid lines, or if the room has a run of 50 panels or more. Long runs (50 panels or more) should be minimized by locating the start point in the middle of the room. This will halve the growth or shrinkage that may result in the installation if it were started in the corner. A middle start point also allows two installation crews to work away from each other and continue the installation in a progressive manner.

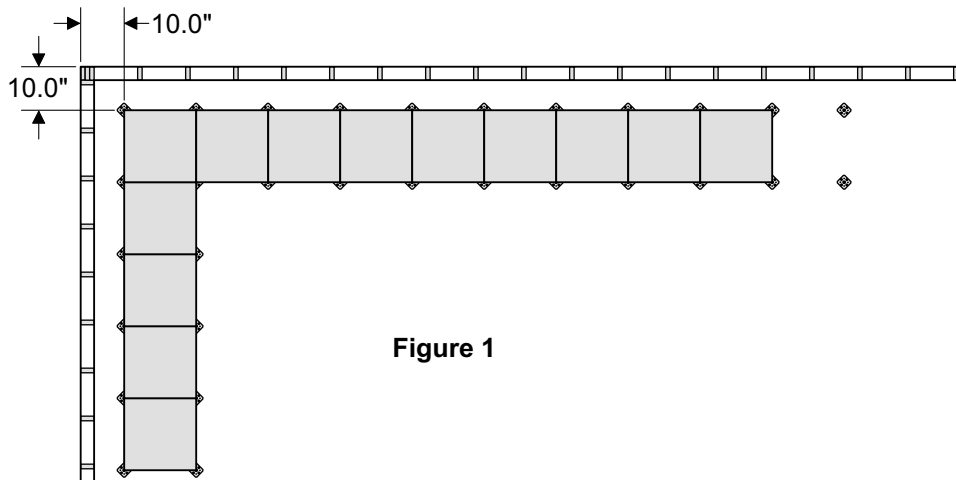

**Figure 1**

Check for the width of the wall cuts by measuring the total length and width of the room.

Verify the distance from the nearest even module (full panels) distance. You can then do one of the following operations to the remainder distance:

Subtract 6" for a minimum cut panel  
( or )

Divide the remainder by two for an equal cut panel dimension

The result provides you with the distance from the wall to the center line of the first pedestal. If you are lucky enough to have square and straight building walls, full panels may be used at the first pedestal line to minimize cut panels. Example: Room width is 123-8"; the nearest even module is 122; remainder distance is 1-8".

Subtract 6" yields 1-2" for the wall to start point dimension  
( or )

Remainder distance is 1-8" divided by two yields 10" from the wall to the start point.

Working from the column center lines of the building requires measuring the distance from the column center line to the walls. All dimensions must be six inches larger than the nearest even module distance. If you must change the start point, be sure to get the change approved in writing by the General Contractor and convey the new start point to the other trades.

## 6. Elevation Checks, Doors, Windows, Stairs, Elevators, Slab Variance

Starting the installation requires that the start point and starting elevation be determined in order to make sure the building surfaces are met, that the layout does not include cut panels at the walls or columns less than 6" wide, and that the pedestals supplied for the job can adjust to the heights required. Make several height measurements of the slab condition at various locations, especially at the center of bays, at columns, at the exterior walls, and between the columns. Once these measurements are made, the elevation required at the start point is determined in cooperation with the General Contractor and a permanent bench mark is established on a column for reference. Finished floor heights above 6" typically have an adjustment range of +/- 1". Lower floor heights have reduced adjustment range, as little as +/- 1/4" at 4" finished floor height. If the height range required is more than these adjustments will accommodate, you will have to do one or more of the following:

- a) order some pedestals of various floor heights;
- b) have the low floor areas filled;
- c) allow the floor installation to follow the subfloor; or
- d) order special pedestals with increased adjustment range or cut the pedestal bases.

If field cutting the pedestal tubes to allow a smaller finished floor height, make sure that the end of the tube is cut square. Angular tube ends will cause the pedestal head to rock. If there are conflicts, make sure the General Contractor knows about them and will have the problem addressed. Please keep in mind that most specifications have standard allowances for flatness of the finished floor installation. Typically these are 0.062" in 10 feet and 0.125" over the entire installation. Deviations from the specification requirements will require approval from the General Contractor, Owner, and/ or the Architect.

## 7. Cleaning the Subfloor

The access floor materials will completely cover the subfloor once installed. Before this happens, the subfloor should be thoroughly swept and vacuumed to remove construction debris, water, and surface dust. This is important in spaces that use the access floor plenum as an air distribution duct.

## 8. Establish Square Lines

Along the longest room dimension, stretch the chalk line through the start point and anchor at an equal distance from the wall or column at the other end of the room and snap a chalk line on the floor.

**Figure 2**

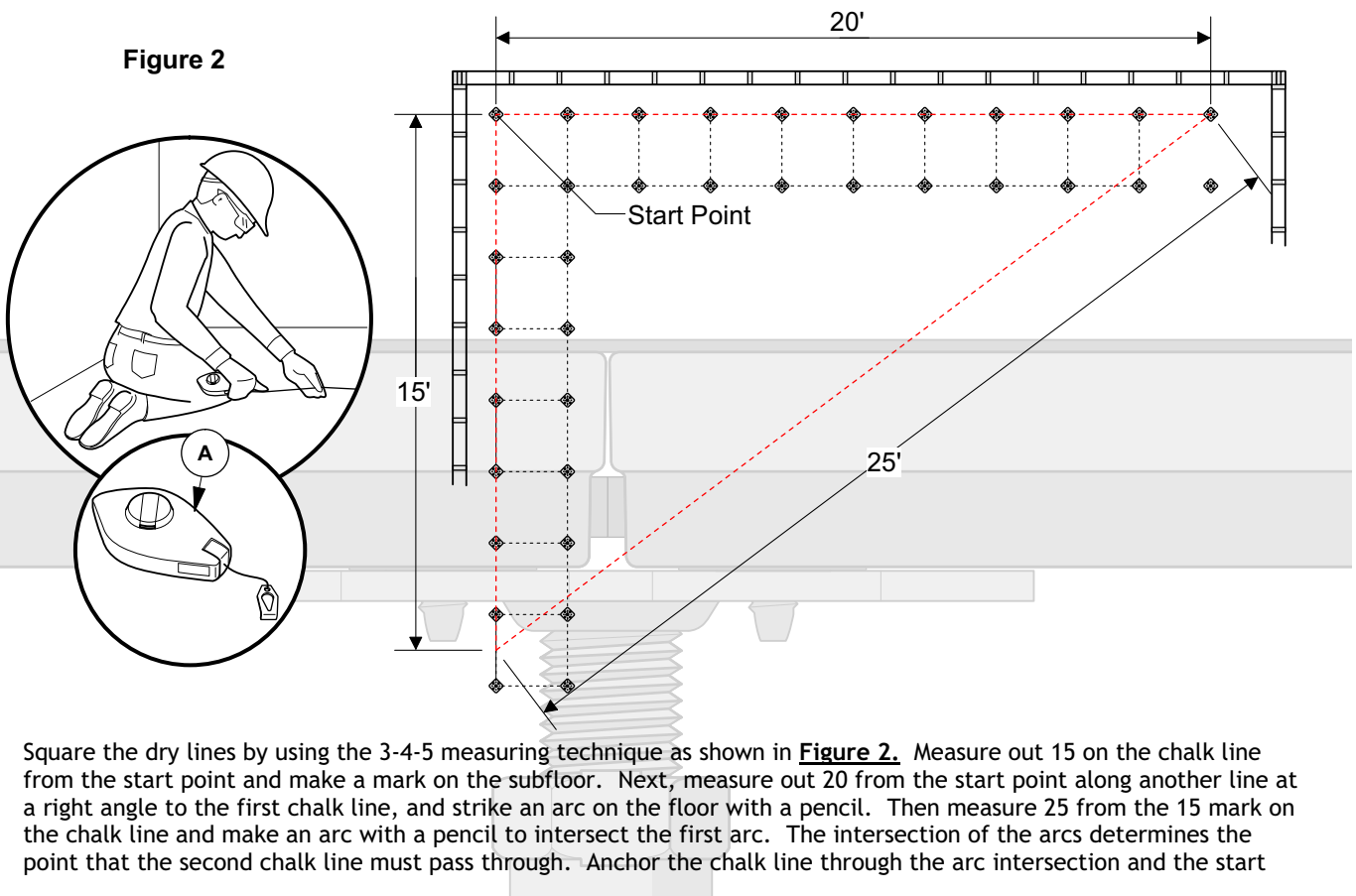

Square the dry lines by using the 3-4-5 measuring technique as shown in **Figure 2**. Measure out 15 on the chalk line from the start point and make a mark on the subfloor. Next, measure out 20 from the start point along another line at a right angle to the first chalk line, and strike an arc on the floor with a pencil. Then measure 25 from the 15 mark on the chalk line and make an arc with a pencil to intersect the first arc. The intersection of the arcs determines the point that the second chalk line must pass through. Anchor the chalk line through the arc intersection and the start

point, and then snap a second line. The chalk lines are now square and establish the edges of the first row of full panels in each direction. Double check the dimensions for squareness and the layout against other features of the building to be sure the square lines are running consistently with the building. Make the 3-4-5 dimensions as long as possible to increase the accuracy of the square. Any multiple of 3-4-5 will work as well (such as 15-20-25 as shown in **Figure 2**). The suggested laser will also square an area by positioning the laser vertically. Be sure to check the square created with the laser by measuring to ensure the accuracy of your installation. Erect the dry lines 1/2" above the finished floor height directly over the chalk lines as a guide to locate the edges of the access floor panels as shown in **Figure 3**. Make sure that the lines are square. It is impossible to fix an out-of-square condition after installing a large section of floor.

**NOTE:** Locate dry lines (B) 1/2" above finished floor height directly over chalk lines (A).

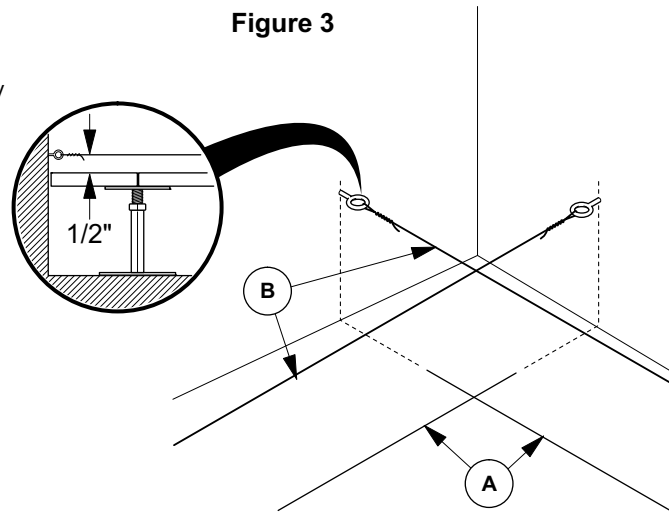

## 9. **Install the Basic ELL**

Finally you are ready to install the first pedestals, stringers, if required (**see Figure 4 below**) and panels in your new installation. Use the laser and leveling bar to adjust two rows of pedestals along each dry line. Place the panels on the pedestals and check for levelness with the two-foot level. Install the panels along each dry line making sure the pedestal center lines are aligned with the string and the system is staying on module length down the row.

**Figure 4**

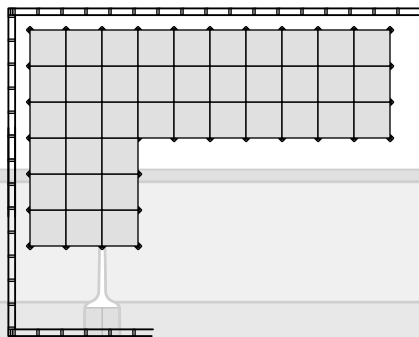

Access floor panels are slightly undersized from the 24" installation dimension to allow for a small gap between panels during the installation. This gap allow for easy exchange of panels after the job is complete, reduces noise created by panel and understructure interference, reduces damage to the edge of panels during installation, and makes it easier for the installer to stay on module during the installation process. The initial rows establish the spacing of the entire installation. Check that the panels are installed on the module marks as the installation progresses. This is especially important if the job site is located in cold climates. Recheck the squareness after the first row is installed. Repeat this procedure for the next two rows of panels, continually checking spacing, squareness, height, alignment with the dry line and level as shown in **Figure 4**.

It is important to prevent other trades from working on or around the first few rows of panels to ensure that the system is not knocked out of square at this early stage. Demand that no one walk on or work in the area of the installation start point for at least 48 hours. This will allow the adhesive to set firmly enough so that the

position of the floor system will not readily move. It is advisable to check the installation at the beginning of each day for squareness during the initial installation process.

After three or four rows of panels are installed along each dry line, it is now time to install the cut panels at the walls as shown in **Figure 5** below. Measure, cut, and shim the cut panels as required. The purpose for installing the cut panels at this point is to provide a brace against which the remaining installation may proceed. If shims are used to account for wall variation, do not force the shim so much that the installation moves from the dry line. A snug fit is all that is required. Adhere the shim in place with pedestal adhesive and remove the excess shim material after the adhesive has dried. A square and firm back bone now exists to complete the installation.

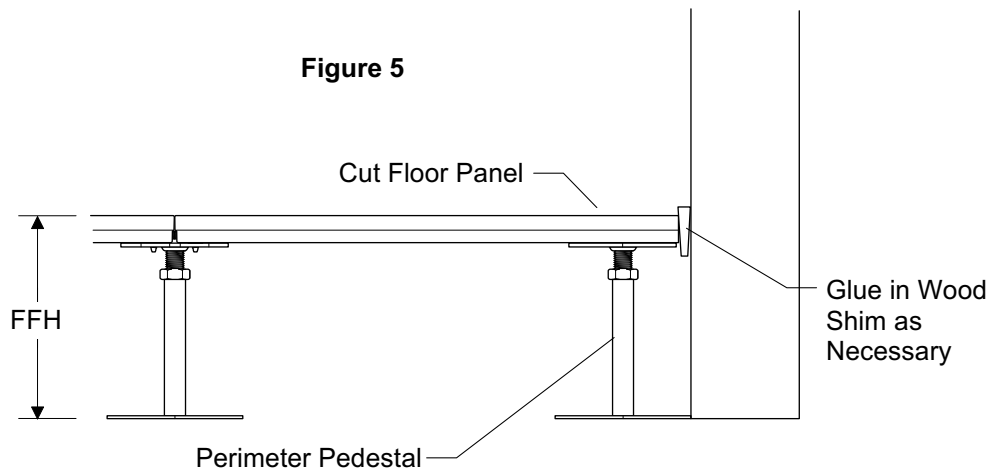

#### 10. **Adhesive Coverage**

Haworth Architectural Interiors standard specifications and many job specifications call for a minimum pedestal turnover performance of 1000 in-lbs. These results will generally be obtained within a reasonable margin of error using a standard base plate and factory applied adhesive. This is based on several factors which must be complied with:

- The pedestal bases are completely covered with adhesive  
Minimum coverage recommendations - adhesive applied to the bottom side of the base plate.

Base Size	Envirotech 105	Sealbond 95	Polyped
4" x 4"	40 g	30 g	25 g
5" x 5"	50 g	37.5 g	38.4 g
6" x 6"	90 g	67.5 g	55.3 g

- The adhesive is fully dried. The drying time is quite variable due to job site conditions.
- The job site conditions conform to the recommended installation conditions.
- Tested concrete sealers have been used and the subfloor is concrete.
- The concrete is clean, dry, and structurally sound.
- Seismic specification requirements may have higher turnover moments and will require consultation with the Engineering Department for the proper baseplate size, adhesive, and/or mechanical anchors to be used.

If some of the above conditions have not been met, lower turnover moments may result. It is advisable to place trial pedestals well in advance of installation time to verify adhesive compatibility, especially if an unknown sealer has been used. Bonding to subfloors other than concrete should be tested on an individual basis by the installer or customer on the job site to verify performance. Please refer to [Chapter 6](#) for instructions on field testing the pedestal bonds.

**NOTE:** Evenly distribute adhesive (D) to bottom of pedestal (C). Continue this process staying no more than one hour installation time ahead of the panel layer.

**Figure 6**

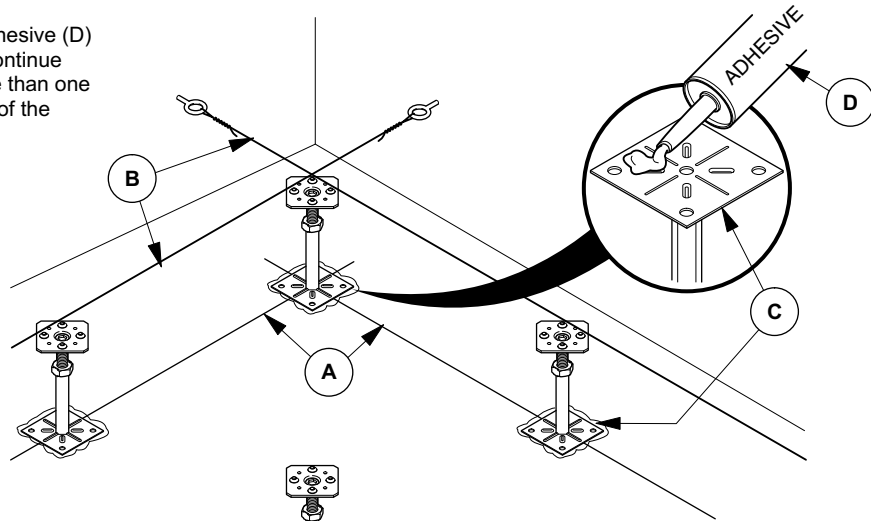

**11. Filling**

The installation of an access floor is a progressive operation. Start off of the basic ELL and finish the room across to the opposite side. Do not attempt to pre-install the understructure and later fill in the panels. The installation will be out-of-square, have gaps between the panels, and may not even allow the panels to be installed. Do not attempt to start the installation from two separate locations and meet in the middle with even panel dimension and matching grid lines. Access floor systems grow and shrink at different rates depending on the method the panel layer uses to place the panels. Independent start points will result in cut panels and/or uneven grid lines.

**IMPORTANT: DO NOT RANDOMLY INSTALL PANELS.**

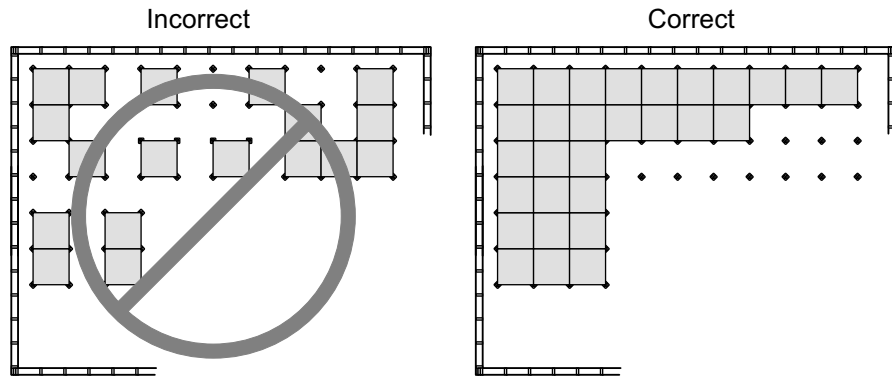

**12. Leveling**

There are three elements used to level the access floor pedestals: the laser, the leveling bar, and the installer. It is easier to control the elevation of the floor system if one person does the leveling for consistent application of the laser beam on the target. Two leveling people will always read the mark slightly different resulting in more effort by the panel layer to control rocking panels. The laser is used to establish the elevation of the primary pedestals which are located at the length of the leveling bar (10 feet for this example).

**Figure 7**

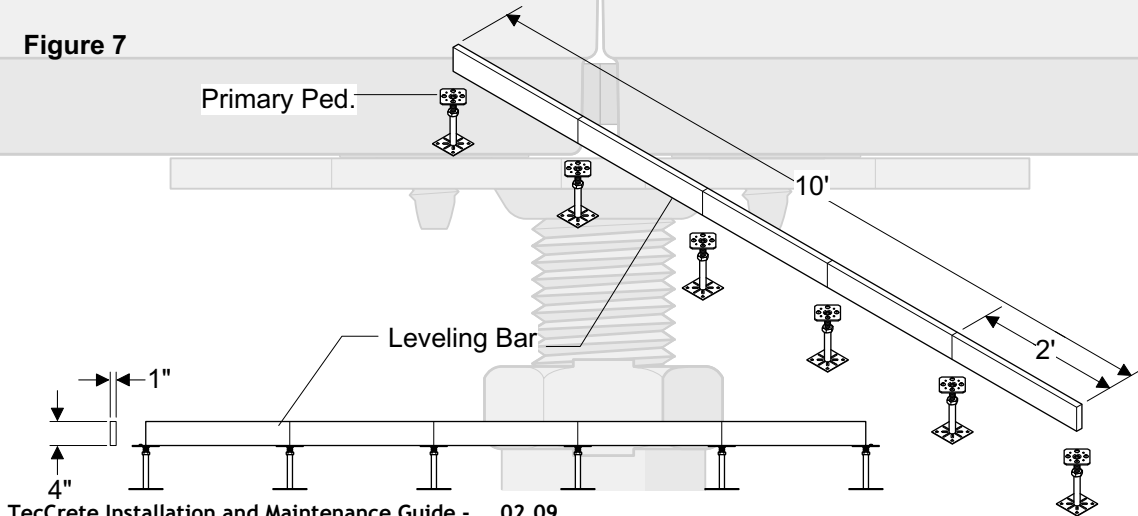



### 13. Tapering the Finished Floor Height

Tapering the finished floor height is sometimes required to meet various building features. The procedure to taper the floor and prevent rocking panels requires planning ahead and careful adjusting of the pedestal elevation. Measure the distance from the installation point to the building feature which the access floor must meet. Divide the distance by the length of the leveling bar you are using to find the number of primary pedestals from the installation to the feature. Divide the total height change required by the number of primary pedestals. This result provides the basic increment that the primary pedestal heights must be changed to mate with the feature. Using the laser, level each primary pedestal to the height required adding the height change to each primary pedestal. Use the leveling bar to adjust the secondary pedestals to the bottom of the bar. The floor will now slope gently to the building feature. Approximately 1/8" height change for every 10' can be achieved using this method. Make sure to get approval from the General Contractor to slope the floor in this manner; you may exceed the allowable overall height change indicated in the specification.

Example: *The doorway at the far end of the room is 3/8" higher than established floor height and is 32' away. 32/(10' leveling bar) is 3 primary pedestals between the installation and the doorway. 3/8"/(3 primary pedestals) is 1/8" rise for each primary pedestal. Set primary pedestal #1 at +0.125", primary pedestal #2 at +0.250", and primary pedestal #3 at +0.375". Use the leveling bar to adjust the secondary pedestals establishing the slope required to meet the doorway.*

### 14. Installing Stringers

The stringers (G) and stringer covers (H), if required, may now be attached to the pedestal heads (C). When installing the stringer screws (J), be sure not to over-torque the screw (a maximum of 40 in. lbs. is recommended). If the stringer profile bulges around the screw head or the end of the stringer flares, the torque setting is too high on your screw gun. Bulges and flare in the stringer may cause interference with the panels preventing the panels from meeting and creating installation noise. Maintain the squareness of the heads with the stringer and module lines. Twisted heads will force the panels out of square creating gaps between panels and rectangles at the intersection of the panels. If you are using the 4' stringers and have a fixture used to attach the heads to the stringers, the stringers will already be in place when you level the pedestals. The 4' stringers will also act as a form of a leveling bar to adjust the pedestals

Load bearing 450 lb. stringers use 1/4"-20 x 1-3/4". The load bearing stringers (G) are offered in either 2 or 4 lengths and require the use of a stringer gasket (H) (included with stringer (G)). ( See items (G) and (C) below.) The load bearing stringers (G) are attached to the pedestals (C) diagonally across the pedestal head. TecCrete pedestal heads are fastened on the corner-lock domes. Do not use the domed holes for the load bearing stringers. They are not on the same center spacing as the holes located on the diagonal.

Take care to make sure that the stringer is sitting flat and square on the pedestal head before fastening to the pedestal head. This could cause noise if not properly installed.

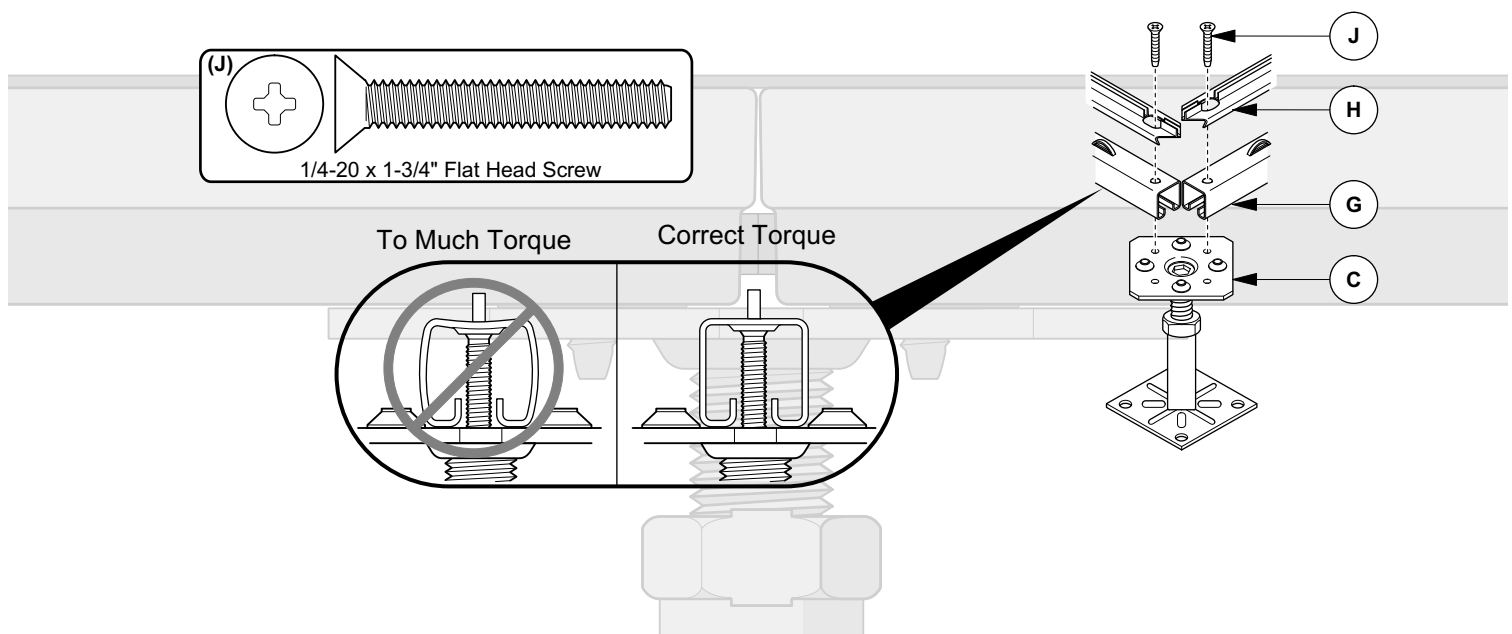

## 15. 2 x 2 Stringers

Two-foot stringers provide the easiest access to the underfloor cavity if new equipment must be installed under the access floor. Stringers and panels adjacent to the work area do not have to be removed as with the longer stringer modules. Two-foot stringers require more effort to maintain the floor squareness during the installation process due to the greater number of joints in the stringers. Assembly of the stringers to the pedestals is usually performed at the point of panel installation. See figure 10 below.

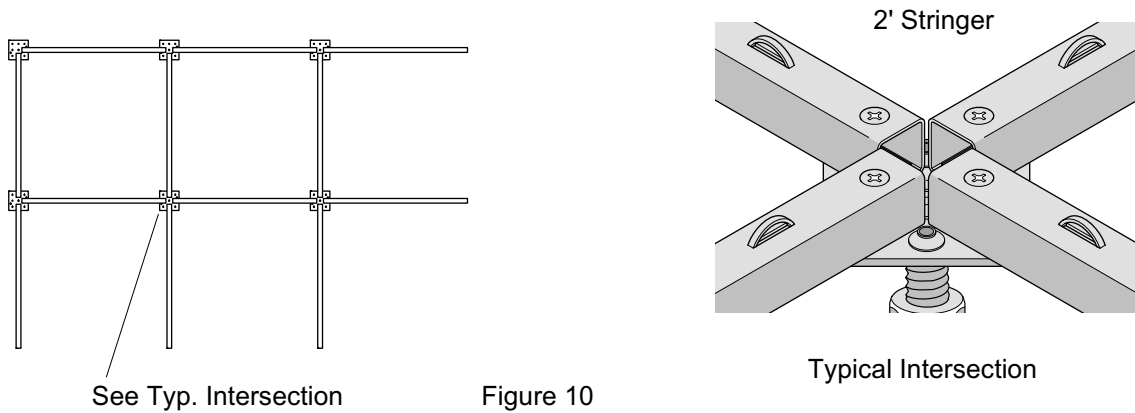

Figure 10

## 16. 4 x 4 Stringers

Four-foot stringers are assembled using a basket weave pattern. Each pedestal head has a 4-foot stringer attached at the midpoint of the stringer length. This system provides superior lateral load distribution, maximum vertical load sharing, and an aid to a square installation. Four-foot stringers complicate underfloor access. A 6-foot wide corridor of panels and stringers must be removed to clear a one-module wide path. (See figure 11 below.)

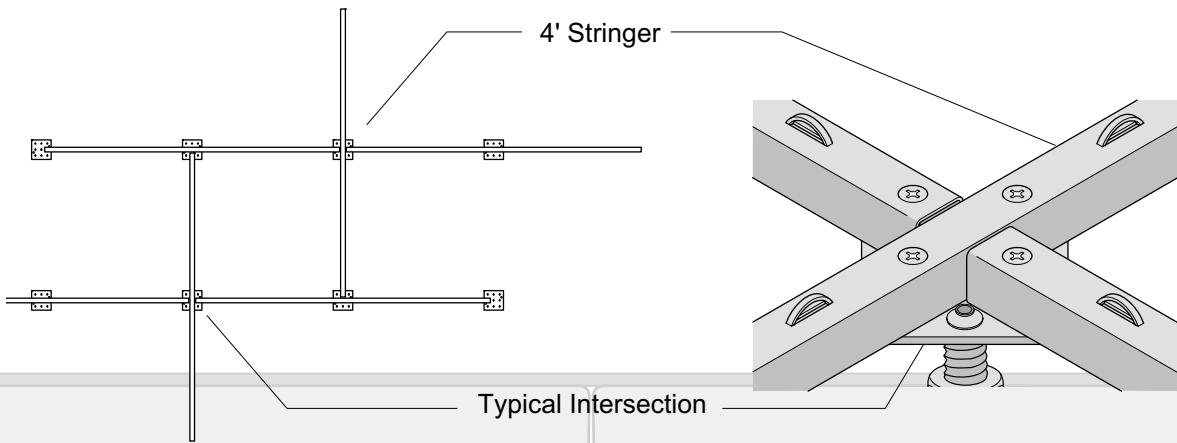

Figure 11

## 17. Installing Stringers at Cut Panels

Stringers may be installed perpendicular to the walls, curbs, etc. by cutting the stringer to the length required for the application. Stringer holes are then drilled in the top of the stringers at the required location and a countersink is formed using a forming tool and a hammer. If stringers are required to be installed parallel with the wall, the perimeter pedestal head and the stringers are used parallel with the wall.

## 18. Grounded Stringer System

Grounding screws are required if the panel to pedestal resistance must be 10 ohms or less. The grounding screw creates contact points between the panel and the pedestal head to create a ground path. We recommend using grounding screws in place of all stringer screws to ensure a fully grounded system.

## 4.2 Placing Panels

The final operation in the basic installation process is to place panels on the pedestals. Be sure to check for panel alignment, squareness, rockers, pedestal alignment, and fine adjustment of pedestal height. Placing panels is typically performed by the most experienced installer on the crew, as the panel layer will control the quality and function of the final installation. The following are some of the key things to look for when installing the panels.

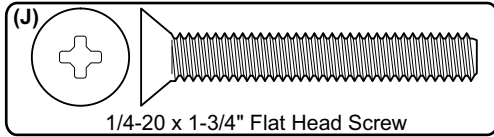

**NOTE:** The height adjusting nut has a bump to prevent the pedestals from changing adjustment as the floor is in use. See "Figure 8" for details.  
Screws should be torqued to 40 inch-lbs.

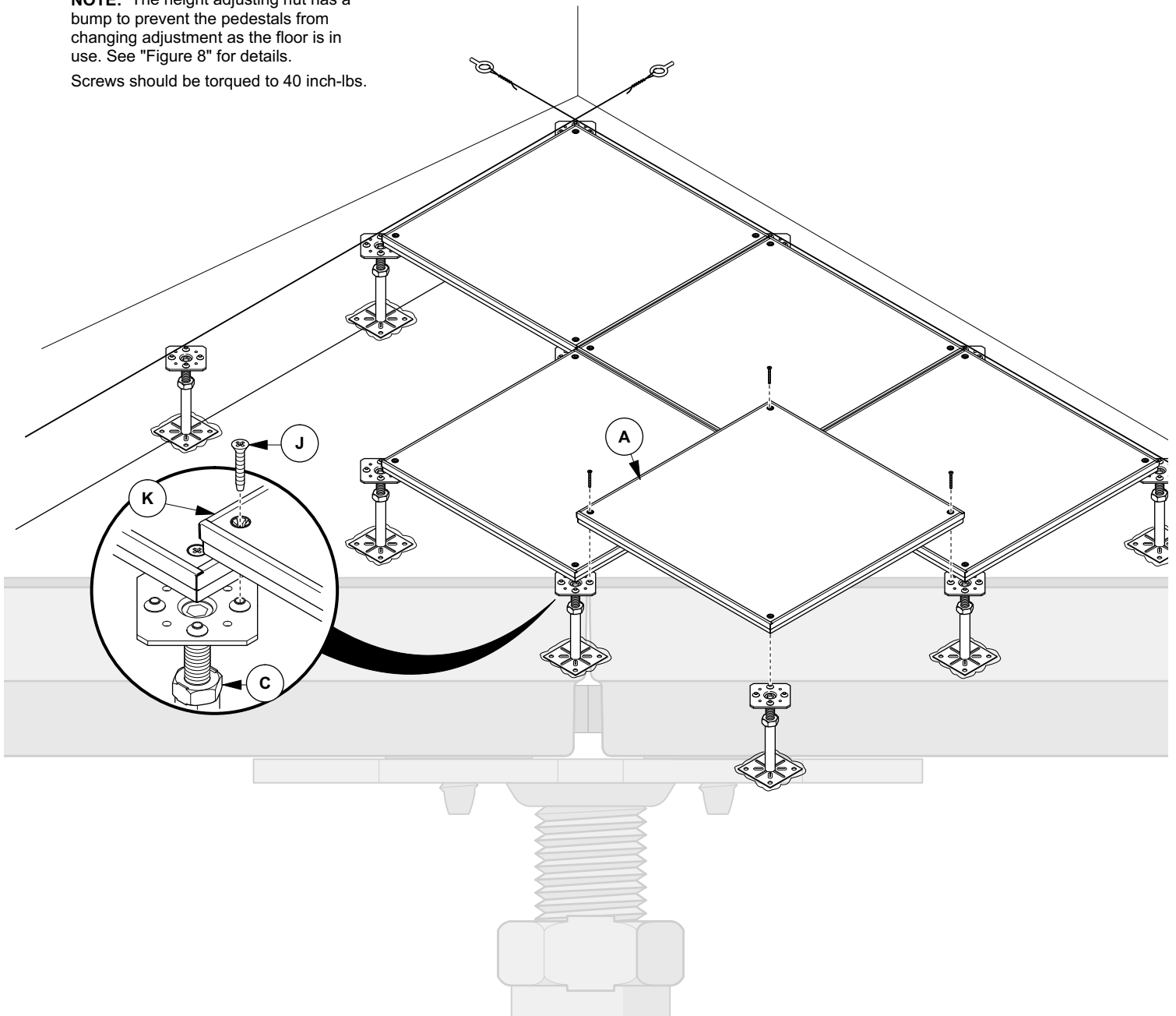

## 1. Panel Spacing

Module lines should be straight and square. Do not force the panels together. A gentle nudge against the adjacent panel is all that is usually required. This helps to maintain the clearance between panels. Remember the panels are slightly undersized to allow for small clearances between panels and maintain the basic panel module size. If the initial rows of pedestals and panels are properly spaced, visually checking the module lines for straightness will help to maintain the panel clearances.

Figure 9

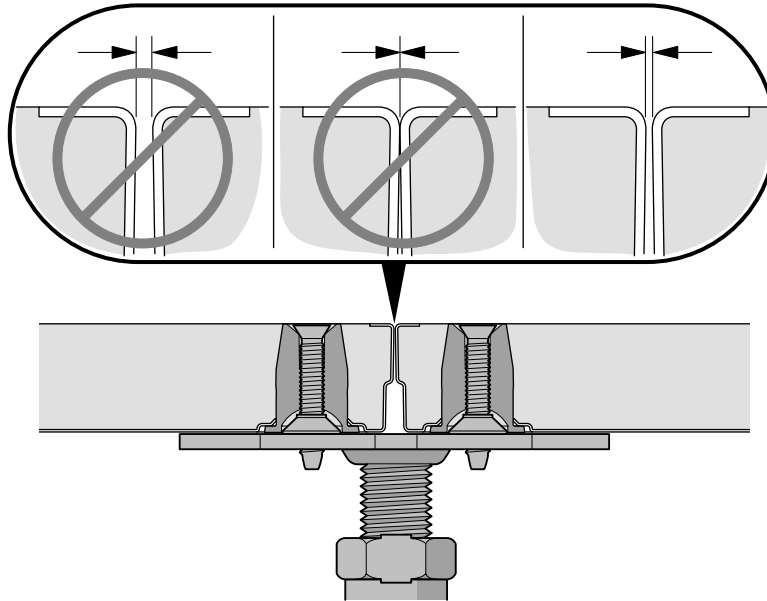

## 2. Corner Gaps

These are rectangular ( rather than square ) openings that can appear at the four corners of panels over the pedestals. They indicate the installation is not square or the panel may be out of square. Generally, these appear gradually during the laying of the panels. You must back up and reinstall the panels where the openings have developed. Continuing to install will make the gaps bigger and the module lines will continue to develop larger steps. Check the dry lines and the squareness of the pedestal heads.

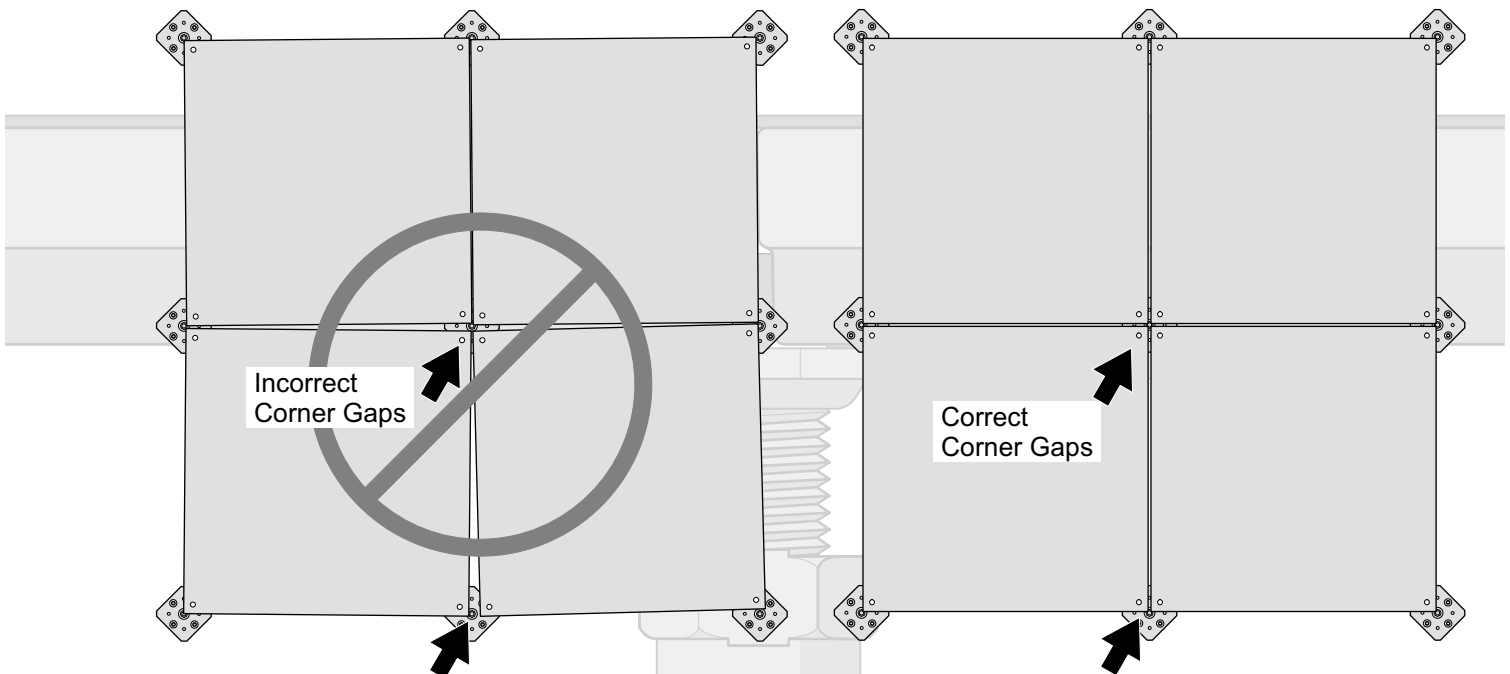

### 3. Adjusting Pedestals

All efforts to resolve rocking panels should be made before adjusting the pedestals. No more than one or two “clicks” (1/4 turn) should be necessary. If you notice that you are adjusting a lot of pedestals, check to make sure the elevation with the bench mark that was established in the beginning is correct and verify with the leveling installer to see if they are leveling consistently. It is easy to force the installation height up or down. You may have to back up and find the spot where the wave in height developed.

### 4. Low Profile Pedestals

This special application of the corner-lock pedestal system is designed for applications where the access floor height is restricted due to the limitation of the ceiling to floor height dimension of the building. There are several special needs that must be observed using this system.

1. Because of the low finished floor height ( 3”- 5”) the under floor cavity is very small. This may require constant monitoring of the under floor clearance to accommodate any wiring devices which are to be installed under the access floor. Some wiring devices may have to be positioned above the access floor to minimize this concern.
2. Low profile pedestals have a reduced adjustment range (+/- 1/4” to 3/8”) depending on the floor height. This may mean some or all of the following conditions may exist:
  - Several pedestal heights may be required to maintain a level access floor.
  - Extensive subfloor elevations will be required, or
  - The access floor may need to follow the condition of the subfloor maintaining a constant plenum height.
3. The pedestals are also configured with the pedestal head threaded directly into a one-piece pedestal base with a 3” diameter bearing pad. This requires the base to be rotated for the fine adjustment of the pedestal system as the head must align with the panel system. It is advised to make all adjustments before applying the adhesive to the base to avoid adhesive transfer to hands, tools, and finishes. It is not necessary to conform to the 1000 in-lb pedestal turnover moments when using an ultra low pedestal due to the low finished floor height. As an example, the most demanding Zone 4 seismic condition will cause a turnover moment of 320 in-lbs at a 4” finished floor height.

### 5. Edge Height of Panels

Check adjacent panels to see if the panels edges are level. Panel to panel edge steps indicate the panel is not flat, the pedestal is tilted, or there is debris under the panel. Check for each and correct as necessary. (See Figure 10)

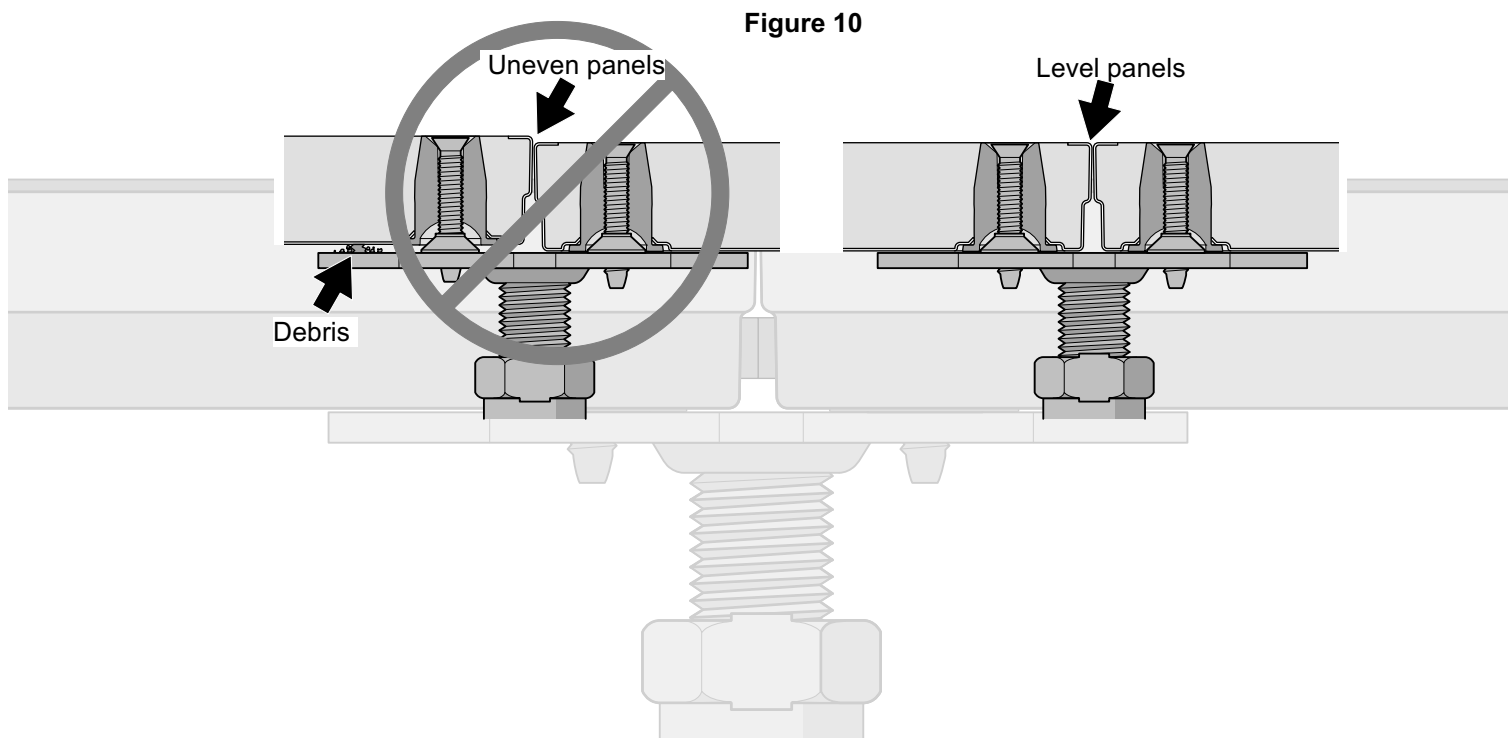

## 5. Square and Plumb of the Pedestal

Typically the pedestal must be shifted slightly to conform to the panels when the panels are placed in the installation. The pedestal base should be firmly positioned on the subfloor, the pedestal head plumb with the pedestal base, and the pedestal head square with the panel module lines. Using a mallet on the pedestals to force the panel against the adjacent panels will cause the system to move out of square. An out of plumb pedestal, as shown below on [Figures 11 and 12](#), will cause unnecessary movement in the understructure and result in a noisy installation. Additionally, a mallet blow can also cause the installation to be excessively tight on corner-lock and bolted grid systems. The mallet will force the parts together and the parts will be held in place due to the friction provided by the fasteners in the panels and stringers. Look for the panel module lines to be straight, the center of the stringer top or pedestal head to be positioned at the top edge of the panels, and the module spacing has consistent dimension.

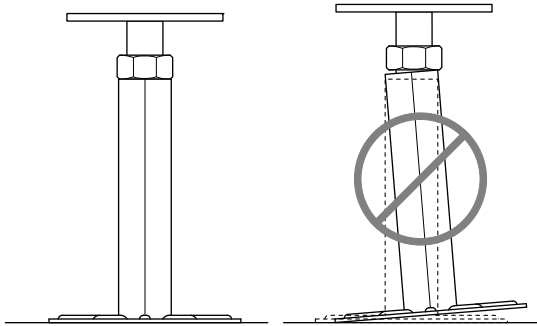

Figure 11

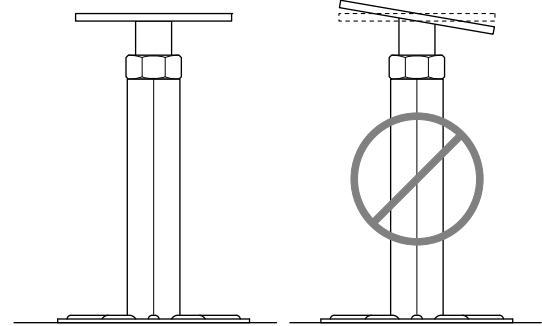

Figure 12

## 6. Working off of the Access Floor Installation

The presence of conduits, pipes, and construction debris sometimes makes it very difficult to transport skids of panels over the job site and work from the subfloor. It may be easier to deliver material to the installation area by carrying materials over the access floor installation. When working on the installation, observe the following habits.

- Do not store the access floor materials in one location. Spread the load out to avoid overloading the building floor.
- Keep the pallet jack and skids away from the edge of the installation area. This will prevent accidental collapse of the floor and avoid injury.
- Schedule the installation and truck arrivals to allow you to install the panels as they are delivered to the area.
- Continually check for squareness and straightness of the module lines. This is especially true for free-standing systems. The rolling loads of the skids will cause the installation to spread.
- Allow the adhesive to cure on the base ELL for at least 48 hours or use a rapid cure adhesive.
- Make sure the pedestals are firmly positioned on the subfloor. Loads applied to thick, fresh adhesive can change the height of the pedestal, causing rocking panels to develop.
- Remember you have just encouraged others not to work on of the access floor installation and you dont want to set a bad example. Make sure the area is safe!

## 7. Use by Other Trades

Inevitably other trades will want to use the access floor immediately after you put the first panel down. Do not allow this to happen. Freshly laid panels can and do shift from their installed position if they are loaded vertically and horizontally while the adhesive is fresh, the perimeter is not cut in, and the free edges of the installation are not restrained. This will detract from the finished quality of the installation in a way that may not be correctable. Excessive gaps between panels, out of square installation, rockers, damage to the panels, and collapse of the floor at the free edge are but a few of the problems which can occur if other workers are allowed to use the floor during the initial set up period. It is recommended that no one be allowed to use the floor for at least 48 hours to allow the adhesive an opportunity to begin curing. It is further recommended that the perimeter cut panels be installed, the free edge of the floor be braced, and the other trades come no closer than four panels from the free edge of the installation with motorized lifts. Heavy carts and lifts may also do permanent damage to the panels. An overlay of at least 1/2" thick plywood should be used to distribute heavy loads if they should occur.

## 4.3 Trouble Shooting and Final Adjustment

After the basic installation is completed, it will probably be necessary to go over the floor and fix some spot problems. Below is a brief listing of some of the more common problems that could be encountered.

### 1. Rocking Panels

Rotate the panel 90 degrees. If the rock stays in the same direction, the pedestals need to be adjusted; if the rock changes direction, the problem is with the panel. Check the bottom edges and corners of the panel for damage or debris. If there is nothing visible, set the panel aside to be used as a cut panel at a wall or column.

Check to see if two or three panels point to one pedestal. A low pedestal will cause all the panels to rock toward it. If the pedestal is high, the panels will all rock around the pedestal. The adjusting nut dimple may be on top of the pedestal tube; rotate the nut until the dimple is at the side of the tube or adjust the pedestal to eliminate the rocker. Be sure you have not created another rocker by adjusting the pedestal.

Check for a damaged panel, pedestal head, or tilted pedestal assembly.

### 2. Corner Gaps (Square vs Rectangular)

These are openings that can appear at the four corners of panels over the pedestal. They indicate that the installation is not square. Generally, these appear gradually during the laying of the panels. You must back up and reinstall the panels where the opening first developed. Continuing to install will make the gaps bigger and the module lines will continue to develop larger steps. Check the dry lines and the squareness of the pedestal heads.

### 3. Causes of System Noise

- a. **Dirt:** Particles between the panels and pedestals, panel and stringers, or stringers and pedestal heads can cause noise to be created when the system is loaded. Remove the dirt and protect the area from construction debris.
- b. **Plumb Pedestal:** Tilted or canted pedestals do not transfer the floor loads directly to the slab as they should. The pedestal head or base (or both) will rotate when a load is applied, causing extra movement in panels, and creating noise. Check for either level panel surfaces at the panel corners, vertical alignment of the adjusting stud and pedestal tube, and firm attachment of the base to the subfloor. You will probably have to reposition the pedestal base, slip the head in the stringer, or loosen several panels in a corner-lock installation to correct the problem.
- c. **Pedestal Head Rotation:** Pedestal heads may be misaligned and are interfering with the panels or stringers. Remove a panel and look for the pedestal head to be out of line with the panel module lines. Tap the head square and retighten any fasteners.
- d. **Adjusting Nut Location:** The locking dimple may be resting up on the pedestal tubes. Rotate the nut off of the tube.
- e. **Vertical Adjustment of the Pedestal:** On systems with stringers or corner-lock systems, the panels may not rock when checked because the stringers will support the weight of the panel easily and can pull the head out of the base slightly. When a load is applied, the nut clicks on the pedestal tube. Adjust the pedestal nut to support the head firmly.
- f. **Pedestal Head Square:** If the panels are flat at the corners and the pedestal base is not plumb, this could indicate the pedestal head is not square with the stud. Determine which way the head should be bent and hit the high side just outside of the stud with a large hammer to straighten the head, or replace the head. It may also be necessary to relocate the pedestal base.
- g. **Excessive Vertical Movement:** Check the subfloor for soft spots such as trench covers, bridging, or defective panel. Replace the panel or support them adequately.
- h. **Damaged Materials:** Check all materials for damage and replace or repair as required.
- i. **Carpet Tile Adhesive:** Carpet tile adhesive that has been poured on or rolled out with excessive material can penetrate between the panels. Once the adhesive dries, it is like a rubber band between moving panel edges and produces squeaks. Remove the panel and clean the edges with a utility knife to remove the built-up adhesive and replace the panel.

## 4. Cutting Panels

After the basic installation is finished, the remaining perimeter panels, column cuts, and equipment cuts may be installed. These panels are unique to their locations and typically cannot be exchanged for another location. All cut panels should be closely sized so that the cove or straight base will cover the cut edge of the panels. It is also advisable to file or rasp any rough edges to prevent injuries which may result from handling sharp edges. If the walls are not straight, more care must be taken to fit the panels to the contour of the wall to avoid gaps. The perimeter cut panels must be properly supported to maintain the system integrity. All cut panels are weaker than full panels, and their strength depends on the size and type of cut. Supplementary support is required at aisleway transitions, for example, to support the loads they will be exposed to. Uncovered panel openings are also a tripping hazard. Mark the location of the holes or cover them to prevent accidentally falling into the openings. Please refer to the Cutting Panel Section of each panel type for equipment suggestions and procedures. (It is recommended that circular, square or rectangular cutouts be done at the factory.)

**NOTE:** Cut all material in another room to prevent sawdust and debris from entering installation area.

**NOTE:** All steel edges should be deburred to eliminate sharp edges.

1.	12.5"	X	10.75"	X	13"
2.	13"	X	23.625"	X	13.5"
3.	13.5"	X	23.625"	X	14"
4.	14"	X	23.625"	X	14.5"
5.	15"	X	"	X	15"
6.	18"	X	"	X	20"
7.	20"	X	"	X	23"

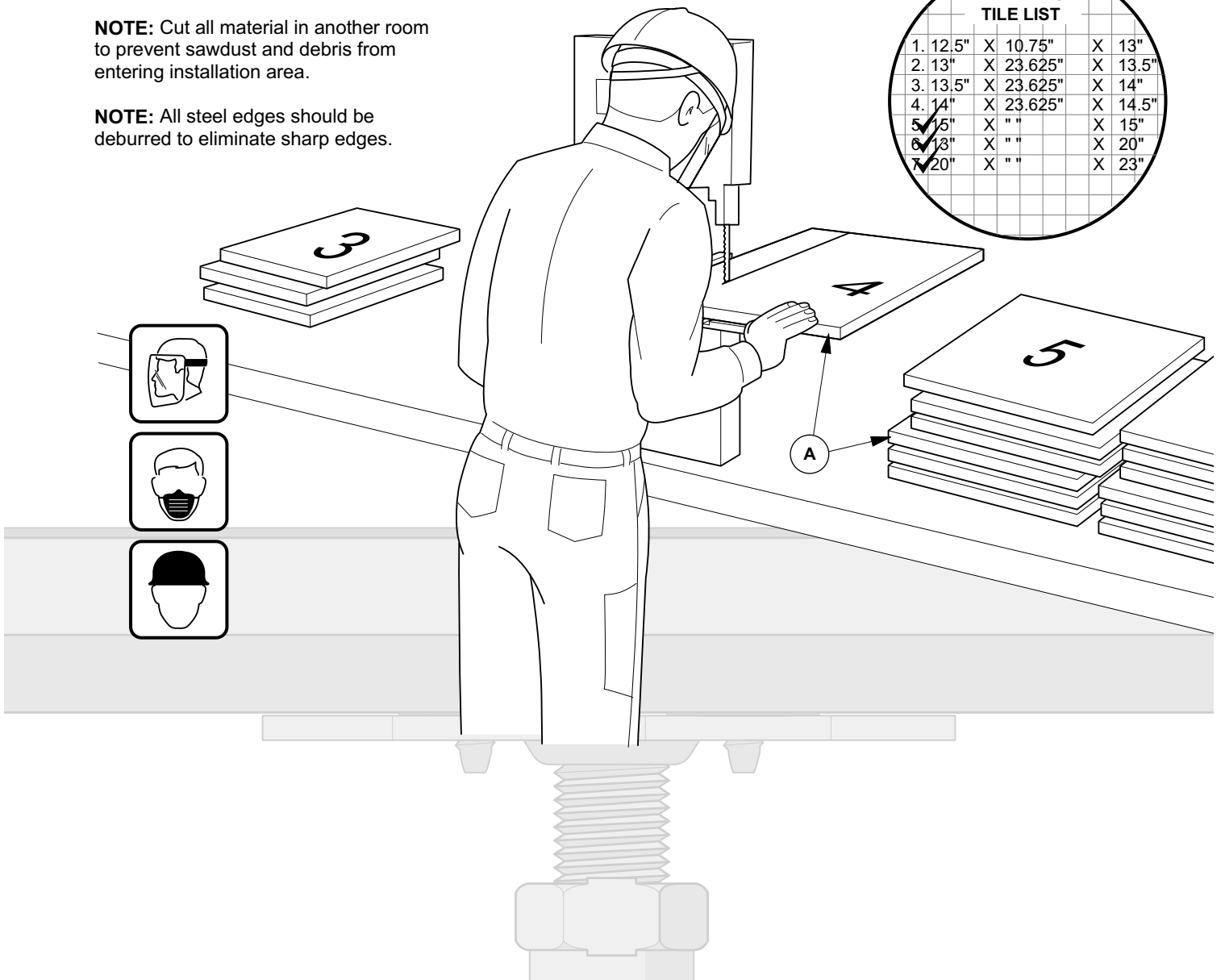

## 5. Protection

After you have received the sign off from the Owner or General Contractor, the Specifications may call for you to provide protection for the access floor materials. Use 20-lb Kraft paper or plastic sheeting over the access floor to protect the finishes and the access floor system from construction debris. Tape the sheet seams especially in the main aisle-ways to prevent tripping or unraveling of the sheet.

## 6. Move-in

During the move-in phase and at any time the access floor will be subjected to heavy rolling loads, the floor must be covered with **minimum 1/2" plywood sheeting** in the path of the rolling loads, depending on the magnitude of the loads. The plywood distributes the weight across a larger area than is covered by an individual wheel or caster. This will prevent damage to panel surfaces and avoid dangerously overloading the floor panels. This procedure should be followed on ramps if they are being used as a conveyance of heavy material over the floor. Generally ramps are intended for pedestrian traffic and should not be used to transport heavy loads without a supplemental overlay.

When using motorized vehicles on top of an access floor, sudden stops and starts and/or accelerations must be avoided. The dynamics of these motions in conjunction with heavy loads could seriously compromise the structure of the access floor. Consult with the Haworth Sales Engineering Dept. concerning specific pieces of equipment.

## 6. Sign Off by the General Contractor

Once you have completed the installation and have gone through the final punch list process, have the General Contractor sign off on the installation. This is your security against damage by other people and will protect you if a dispute should arise. A sample Sign Off Sheet has been provided for your use on the following page. **(Make sure that this signoff sheet is kept in your job file for reference should a problem occur.)**

On larger projects more than one signoff sheet maybe required. As you complete and area or floor and before turning this area or floor over to the other trades request that the owner or general contractor sign the form releasing you from that area. At that point it becomes the owners or general contractors respond ability to care for the installed floor.

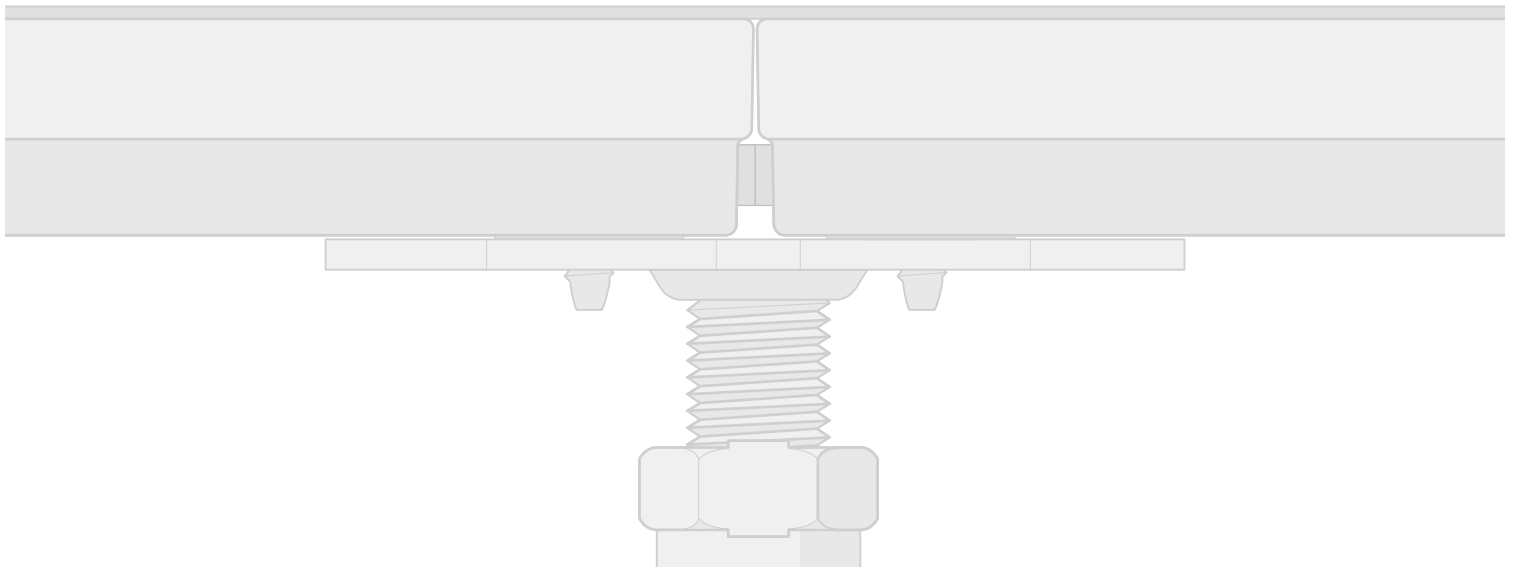

## 4.4 Access Floor Installation Acceptance and Sign Off Sheet

Access Floor (Sub) Contractor: \_\_\_\_\_

General Contractor: \_\_\_\_\_

Project Name: \_\_\_\_\_

Contract Number: \_\_\_\_\_

Area Number: \_\_\_\_\_

Date: \_\_\_\_\_

We have reviewed the access floor condition and installation quality of the above project or area and have found it to be complete and in accordance with the Project Specification.

The following exceptions are noted: \_\_\_\_\_

\_\_\_\_\_  
(signed) Authorized Representative for the General Contractor

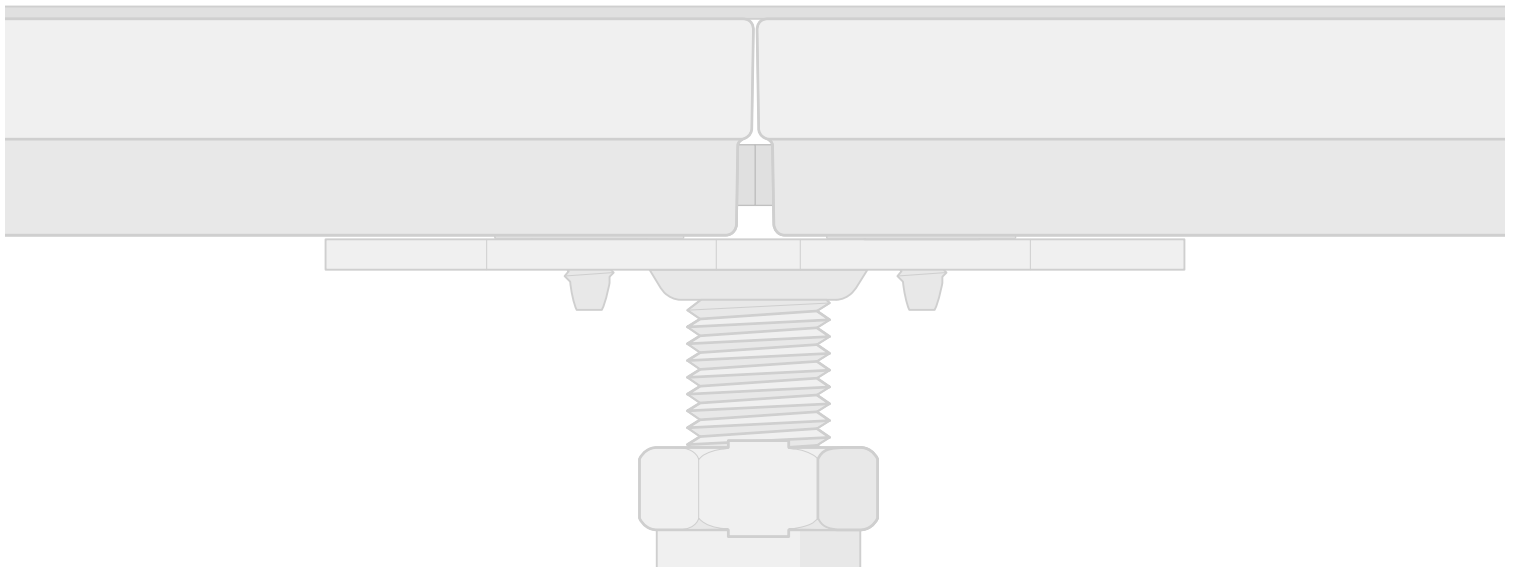

## 5 SCREWS AND FASTENERS

### 5.1 Panel and Stringer Fasteners

Haworth Architectural Interiors utilizes varying sizes of fasteners for corner-lock panel systems and stringer attachment. The panels and stringers are countersunk to accept specific size fastener heads. Make certain that the correct size fastener is available and is being used to prevent damage and to provide for proper seating of the fasteners. Listed below are the descriptions of the fasteners used in the various systems.

TecCrete 1250 uses 1/4"-20 x 1-3/4" and 2" long fasteners for corner-lock application. These fasteners should not be used to pull the panel or pedestal heads together. Correct out-of-level conditions by adjusting the pedestal nut or repositioning the pedestal assembly. Using the fasteners to pull the parts together can cause the TecCrete corner to crack, pull the fastener through the screw hole, strip out the screw drive or the screw threads. All corner-lock fasteners should be tightened to 40 in-lbs maximum. We recommend using a battery powered, adjustable torque, screw gun to help you control the load applied to the fasteners. An adjustable depth control screw gun (dry wall screw gun) can be used successfully if the depth of penetration is set correctly. Dry wall guns do not control the torque or guarantee that the fasteners will be tight. Therefore, some failures and/or loose joints may result. Adjustable torque limiting screw guns manufactured by Black & Decker, Hitachi, and Mikita have proven to be effective for the installation of corner-lock fasteners.

#### 1. TecCrete 1 1/8" Panel Corner Lock:

1/4" x 20 UNC x 2" long flathead screw with a # 2 Phillips drive head.

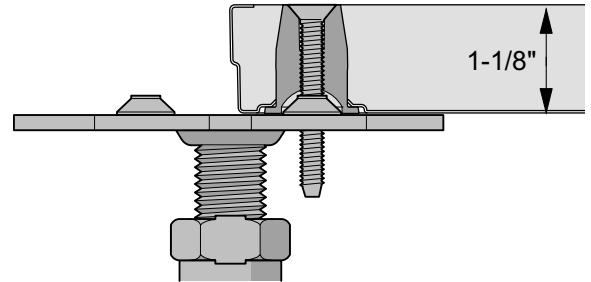
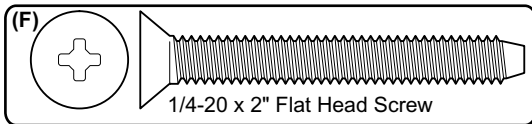

#### 2. TecCrete 1 1/2" Panel Corner Lock:

1/4" x 20 UNC x 2" long flathead screw with a # 2 Phillips drive head.

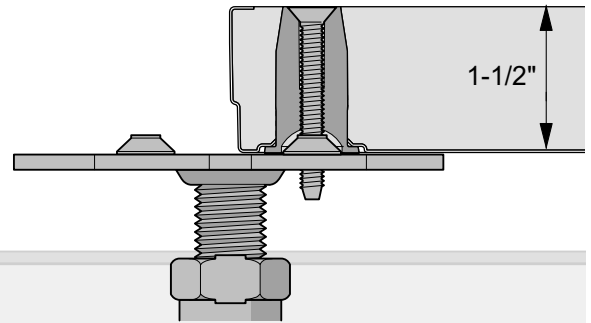
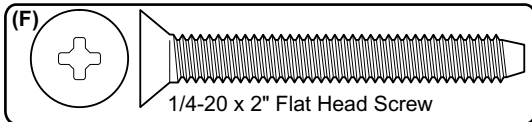

#### 3. TecCrete 1 1/8" Panel Corner Lock with Load Bearing Stringer:

1/4" x 20 UNC x 3.5" long flathead with a # 2 Phillips drive with a # 23 type dog point.

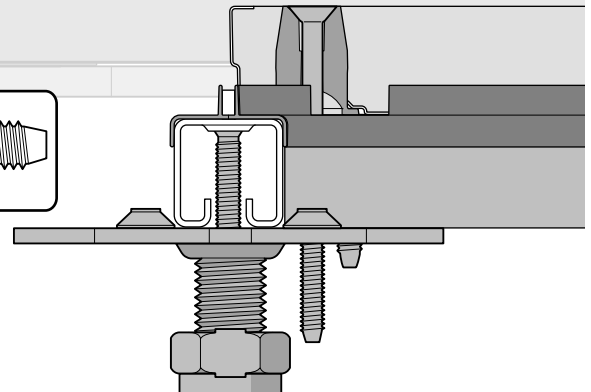
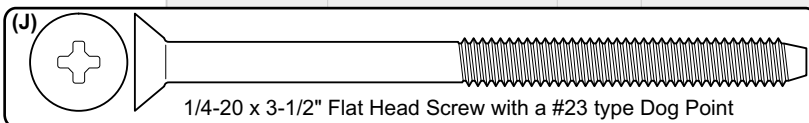

4. **TecCrete 1 1/2" Panel Corner Lock with Load Bearing Stringer:**  
1/4" x 20 UNC x 3.5" long flathead with a # 2 Phillips drive with a # 23 type dog point.

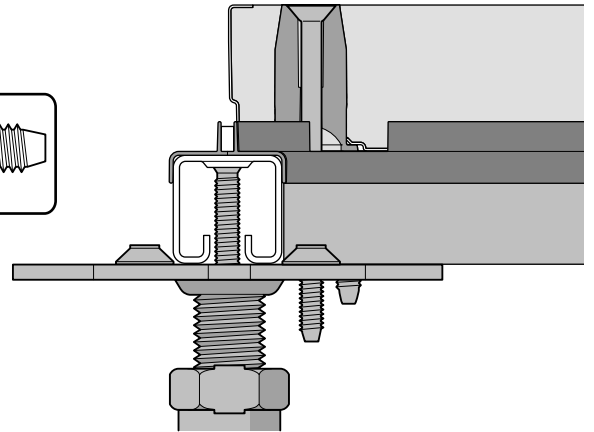
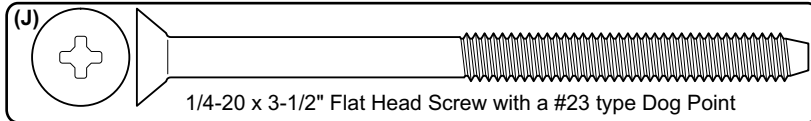

5. **TecCrete Grounding Screw :**  
1/4" x 20 UNC x 1-3/4" long flathead screw & washer with a # 2 Phillips drive head.

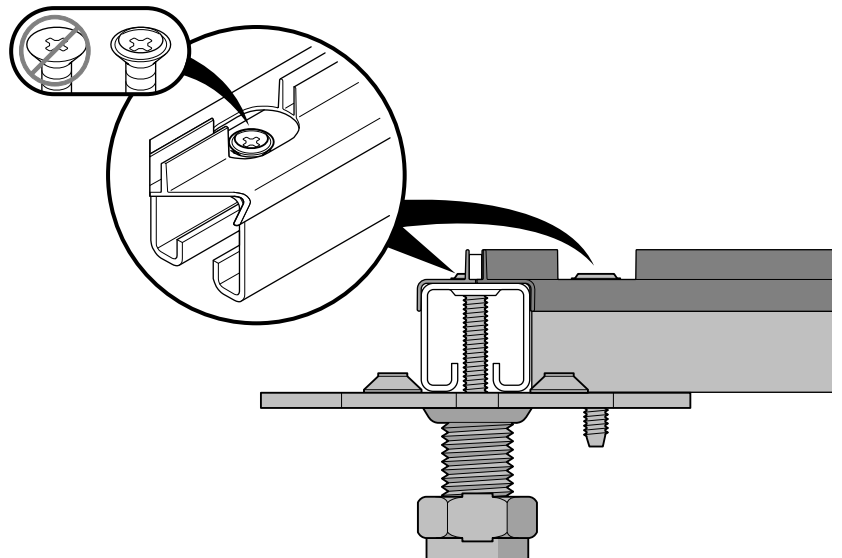
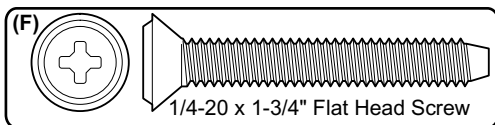

6. **350-lb. Edge Support Stringer:**  
1/4" x 20 UNC x 1-3/4" long flathead with a # 2 Phillips drive head.

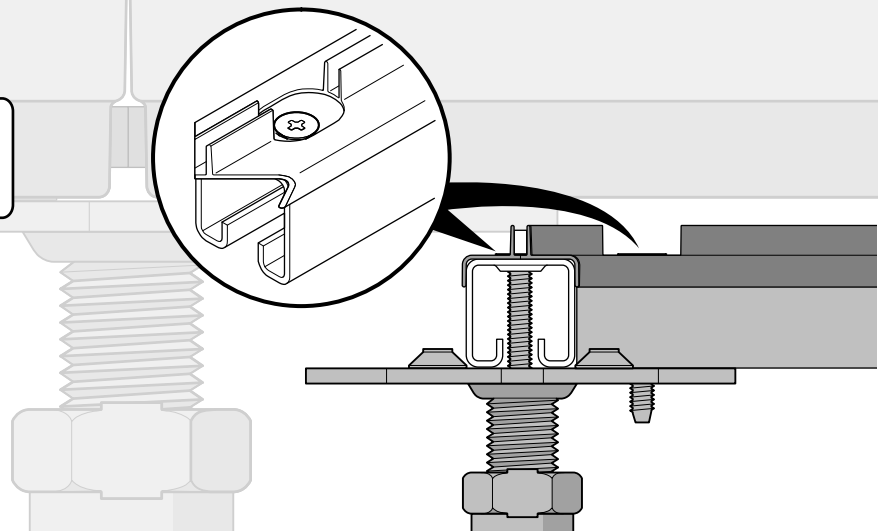
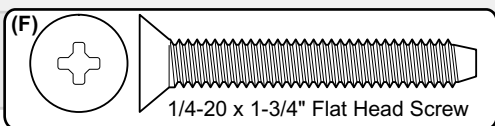

## 5.2 Mechanical Anchors for Pedestals

It may be desirable to have the pedestal bases attached using a mechanical anchor instead of adhesive alone in seismic zones, sloped floors, and for high finished floor heights. Powder actuated fasteners (short pins) are not recommended as a method to attach access floor pedestals in these critical situations due to the inconsistent nature of their holding power. Drilled in (Hilti Kwik-Bolt or equal) and screw in (Tapcon or equal) are recommended for these applications. Sizing and specific recommendations can be provided by Engineering as needed. When installing the access floor with mechanical anchors, it is also recommended to use a pedestal adhesive under the pedestal to compensate for any subfloor variation. The mechanical anchors should be installed after the adhesive has cured extensively. The adhesive prevents the base from conforming to an irregular concrete surface as the fasteners are tightened. Tightening the anchors will force the pedestal to conform to the contour of the subfloor which may cause rocking panels and loss of module dimensions

Wedge Anchor

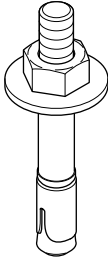

Tapcon Cement Screw

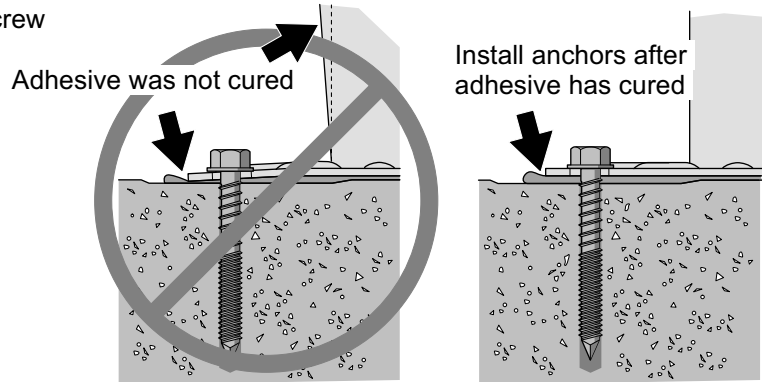
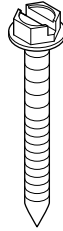

## 5.3 Attaching to Panels

Often attaching architectural elements, such as wall tracks, to the access floor panels is required. Shot pins with a maximum diameter of 0.188" may be used for these situations provided they are adequate for the job and are located 3" away from the edge of a panel. Expansion type anchors are not recommended for any application when attaching to the panels. Pressure from the expansion anchors may cause the concrete to crack and result in poor attachment. The best method is to through-bolt the elements to the panels with a nut and washer, and again a minimum of 3" away from any edge is recommended.

Shot Pin

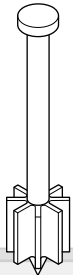

Through-Bolt

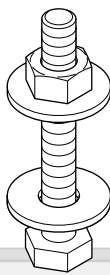

Wedge Anchor

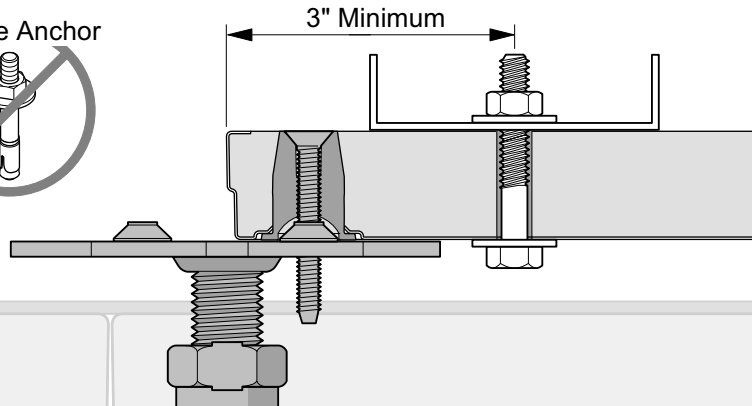

## 6 SUBFLOORS

A variety of subfloors are encountered under access floor installations. Listed below are the most typical types and some of the pitfalls encountered with each.

### 6.1 Concrete

Concrete is the most common building surface and generally does not present any installation difficulties. Dusting, surface flakes, and irregular finish present bonding and adjustment concerns. The pedestals must have a clean hard surface for effective bonding. Dust, water, grease, and dirt prevent good adhesion.

### 6.2 Sealed Concrete

Computer rooms and spaces using HVAC in the plenum will generally have a sealer applied to the concrete to harden, dust-proof, and waterproof the concrete surface. There are hundreds of these products on the market. We have provided a short list of sealers that the standard pedestal adhesive has been tested with. If you are required to provide certified turnover performance on your project with another sealer, please consult with Engineering and do a physical test. This will take at least 60 days due to the drying or curing time of the adhesive, assembly of materials, and the certified test reporting time. Please plan appropriately.

## Tested Concrete Sealers

Brand Name	Company
Super Trete 110 Cure & Seal.....	Cresset Chemical Co., Weston, OH 43569 (cresset.com)
EUCO Aqua-Cure VOX.....	Euclid Chemical Co., Cleveland, OH 44110 (euclidchemical.com)
OKON Seal and Finish (W-1).....	Rust-oleum Corp. Vernon Hills, IL 60061 (okoninc.com)
1125 Silicate Cure .....	Edoco by Dayton Superior, Kansas City, KS 66106 (daytonsuperiorchemical.com)

### 6.3 Wood

Wood subfloors are mostly encountered in renovation projects. Attachment of the pedestal bases can be a problem due to dirt, grease, wax, and varnishes. Generally, you should clean the spots where the bases are to be located for positive attachment by sanding or grinding. Screw attachment of the pedestals is also possible depending on the condition of the subfloor. Another problem encountered with wood subfloors is flexibility. The subfloor may move so much when loads are applied that the panels will not stay level, causing installation noise due to the movement of the subfloor.

### 6.4 Tile

Vinyl floor tile can be used beneath access floors but turnover performance cannot be predicted and the adhesive drying rate is very slow. The tile adhesive will be old and weak allowing the tile to pull off the subfloor. It is recommended to remove the tile in the pedestal locations. Caution should be used if the tile is reinforced with asbestos. This may be typical in many older buildings. Professional certified removal and disposal of the tile will be required. Drill-in anchors can also be used, but again, the asbestos dust from the tile must be properly handled.

Hard ceramic floor tile is seldom encountered but should be removed along with the existing mortar and grout. This tile would be too brittle to even accept mechanical anchors or other drilled inserts.

### 6.5 Metal Sheeting

Metal Sheeting is principally used in locations with high security. The sheeting blocks electromagnetic radiation from penetrating or escaping the area. Aluminum or copper foils do not provide adequate attachment for the access floor pedestals. Steel sheeting will have buckles and air pockets between the sheet and the subfloor. These conditions do not provide firm footing for the access floor installation and will allow movement in the installation. Solvent based pedestal adhesives do not dry as the solvents are trapped between the pedestal base and the sheeting.

### 6.6 Testing Pedestal Adhesives on Site

Testing the sealer and adhesive combination on the site may be the only way to evaluate the bond in a timely fashion. You should select a spot to adhere the pedestals that will not be disturbed for a period of 60 days, is clean and dry, (away from outside walls) and is as warm as possible to speed the cure of the adhesive. A barrier can be erected to protect the pedestals from accidental loads and from curious people. If the bond line is disturbed during the drying period, the pedestal cannot be reattached to provide the maximum turnover performance. Because you cannot predict how the adhesive will cure due to the sealer, temperature, humidity, and water content of the concrete, you will need to bond 8 - 10 pedestals down in order to have five pedestals for certified testing. The remaining pedestals will be used to evaluate the status of the bond prior to certified testing. Remove the entire excess adhesive at the perimeter of the base to expedite the curing process and firmly locate the base on the floor. After three weeks, break one of the pedestal bonds and examine the adhesive, concrete sealer, and the concrete looking for the following features:

- If the adhesive is cured, the adhesive will be hard and there will be a minimal amount of solvent smell in the adhesive. Let the adhesive set for another week and then do the test.
- If the adhesive is still pliable, especially in the center of the base, curing is not complete. After three weeks this indicates that the drying process will take a much longer period. The adhesive will always harden from the outside of the base to the center. The point where the adhesive becomes harder will give an indication of the drying time remaining. This can only be evaluated immediately after the bond is broken.
- Examine the concrete sealer removing the soft adhesive and the hardened adhesive from the concrete. Has the sealer bubbled, softened, or dissolved? These are signs that the sealer and adhesive are not compatible. You may want to use another type of adhesive such as water-curing polyurethane or a 2-part epoxy product. Follow the same procedure to verify compatibility with these products. These products harden by a chemical reaction creating full strength bonds in a much shorter time frame.
- If the sealer is only softened, has it re-hardened and bonded to the concrete at the perimeter of the base? If so, an extended cure time may be all that is required. Check another base in two or three weeks.

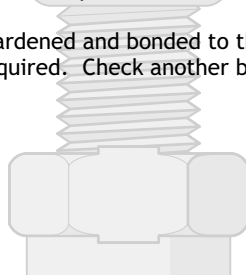

- The pedestals should be pulled over using a calibrated force gauge, preferably one with a dead hand to mark the maximum force applied to the pedestal. Use a constant, steady, pull or push against the pedestal base off of the subfloor recording the maximum load and the height the load was applied above the subfloor. The turnover moment will be the height the load was applied above the subfloor multiplied by the force used to break the bond. You should have at least five test specimens and average the results of the tests according to CISCA Test Procedures. Some specifications may require that the minimum pedestal turnover moment on all of the pedestals be over a given amount. Review the specifications for what is required for this test. ( See Section VI Pedestal Overturning Moment Test per CISCA Test Procedures Dated 2007 )

## 7 CUTTING INSTRUCTIONS

### 7.1 Cut-Outs

It is recommended that cutouts be made at the factory. Cutouts should not be located closer than 3" from any panel edge. Most common is for cutouts to be centered in a quadrant of the panel to allow the cutout location to remain the same when the direction of the panel is changed.

Edge cutouts depending on the size of the cutout and the location where the panel will be installed may require extra pedestals along side the cutout to support the edge of the panel.

Panels with cutouts should never be installed in high foot traffic or heavy rolling load areas.

Cutouts for electrical boxes should be located under the desk and cutouts for air diffusers should be located along the perimeter of the building or in the office cubical but away from the casters of chairs.

Remember to send along with your purchase order to customer service a drawing showing the size and location of all cutouts required.

Should cutouts be required to be done in the field make sure that you have the proper power tools required to make these cutouts.

#### 1. **Straight Cuts**

Cuts which are to be made in a straight line, i.e., without a radius, and including cut lines which intersect, such as cutting a complete corner section out of a panel, can be accomplished using either a circular saw, wet circular table saw, or a band saw. All cut lines at 90 degrees should end in a drilled hole to minimize cracking of the panel at the corner. The following is a list of suggested equipment and the procedure for using each type of tool.

*All steel edges should be deburred to eliminate sharp edges.*

##### a. **Circular Saw**

A worm gear driven saw with a diamond or carbide tipped blade is an economical method for cutting panels. All cuts with circular blades on concrete panels should end in a drilled hole to minimize cracks at the corner of the cut. An overrun at an angle can cause the concrete panel to crack at the corner. You can prevent the overrun by finishing the cut off with a bayonet saw in the corners. The circular saw will produce some dust. Locate the saw where the dust can be contained and cleaned up.

- Suggested Circular Saw: Model 77 Skilsaw, 7-1/4" diameter, 13 amp, and worm drive. Available nationwide from distributors of the Bush Powertool Company, 4300 West Peterson Ave., Chicago, IL 66046, telephone 773/286-7330.

- Suggested Diamond Saw Blade: Diamond dry cutting segmented blade, 7" diameter x 0.080" with 5/8" arbor. Available nationwide from distributors of Diamond Products, Inc., 333 Prospect St., Elyria, OH 44035, telephone 440/323-4616.

##### b. **Wet Circular Table or Radial Arm Saw**

When job site conditions allow wet cutting, this method can save you time and increase the life of the blade. Wet cutting with a table or radial arm saw provides straighter, cleaner, and dust-free cut panels. Corners should also end in a drilled hole and the cut finished with a bayonet saw to prevent the corner overrun of the circular blade. After completion of the cut, the panel should be cleaned and allowed to dry before stacking or installing the cut panel in the floor. These saws are used in the concrete block, brick, and pavers installation industry.

- Suggested Table Saw: Target Stone Matic ( Manufactured by Target Ind. )

- Suggested Saw Blade: 10-12 inch Diamond Tooth Blade

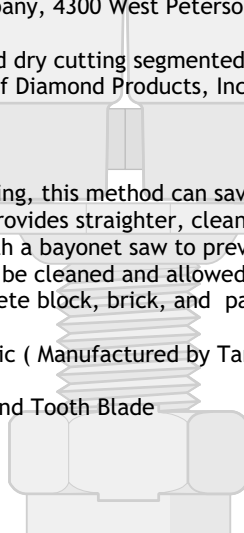

## c. Band Saw

A band saw can also be used for straight cuts. Again, the corners of the cut should end in a drilled hole to minimize cracking. A minimal amount of concrete dust is generated by this method. Dust control by using a vacuum dust collector is optional.

- Suggested Band Saw: Mobile Applications Model MA-615, Zepco Incorporated, 5415 Perry Dr., Waterford, MI 48329, telephone 248/674-8450. This saw has a 24" throat, weighs only 120 lbs and is portable.
- Suggested Band Saw Blade: Simonds 3/4" or 1/2", 3 teeth per inch, Simonds Type 1 Carbide Tipped Band Saw Blade, telephone 1-800/328-3808, or Remington "Grit Edge" Tungsten Carbide 1/2" gulletted, coarse blade. For a radius less than 1-3/4" use 1/4" wide blade. The blade should be run at 260 feet per minute. Available from distributors of the Remington Arms Company Abrasive Products Division, Bridgeport, CT 06602.

*Straight cuts should be at least 3 inches wide at the edge of the panel.*

## 2. Radius Cuts

Cuts on a radius can be made with a band saw utilizing the same band saw equipment and procedures as that listed under straight cuts or with a power drill motor and a masonry drill or by using a core drilling machine with a concrete core bit. The masonry and core bits are run dry. A commercial grade vacuum with a wide mouth attachment placed in close proximity to the concrete core drill or core bits should be used for dust control. All edges should be deburred to eliminate sharp edges.

- Suggested Masonry Drill: 5/8" carbide tipped with 1/2" or 3/8" shank. Available nationwide for distributors of the Cleveland Twist Drill Co., Cleveland, OH.
- Suggested Core Bits: Core bits range in size from 1/2" to 10" diameter. Available from Diamond Products Inc., 333 Prospect St., Elyria, OH 44035.
- Suggested Core Drilling Machine: Core Bore Model M-3. Available from Diamond Products, Inc., 333 Prospect St., Elyria, OH 44035.

*Radius cuts should be made at least 3 inches from the edge of the panel.*

## 3. Interior Cuts

An interior cut is defined as a four sided cut completely surrounded by the panel. This can be made by drilling each corner of the area to be cut out using a carbide tipped masonry drill. Then using either a circular saw with a dry diamond segmented blade, wet saw, or an orbital bayonet saw to cut from hole to hole. Drilling the corner holes is required to minimize the cracking in the panel at the sharp corner created by two straight cuts.

- Suggested Blade: Simonds 1/2", 3 teeth per inch Simonds Type 1 Carbide Tipped Band Saw Blade, telephone 1-800/328-3808, or a Remington SS4-3C 1/2" wide x 4" medium core grit blade.
- Suggested Saw: Milwaukee Sawzall or a Black & Decker Pro Orbital.

*Interior cuts should be made at least 3 inches from the edge of the panel.*

## 4. Carpet Tile Adhesive

Carpet tile adhesive can be applied to the surface of TecCrete panels without problems provided the application of the adhesive is controlled and that the adhesive is allowed to dry before applying the carpet tile over the adhesive. Excessive amounts of adhesive applied at the edges of the panels will cause the panels to be adhered to one another making it necessary to cut the adhesive between the panels to remove the panels. A thick adhesive line also takes longer to dry and can result in oxidation of the panel due to entrapped water in the adhesive. Most carpet tile adhesives use water as the emulsifier and are slightly acidic, if the adhesive does not thoroughly dry before the carpet tile is applied, the water and acidic nature of the adhesive may cause the top surface and the perimeter of the TecCrete panels to slightly discolor. This can only be avoided by making sure the water has completely evaporated before the carpet is applied. If the adhesive build up between panels does dry, the panels may squeak when walked on due to the hardened adhesive rubbing between adjacent panels as loads are applied to the panels.

These problems can be controlled by spraying a film of adhesive across the panel surface or using the more common method of rolling if the adhesive is leveled on the roller before attempting to spread the adhesive on the panel surface paying particular attention to the panel perimeters.

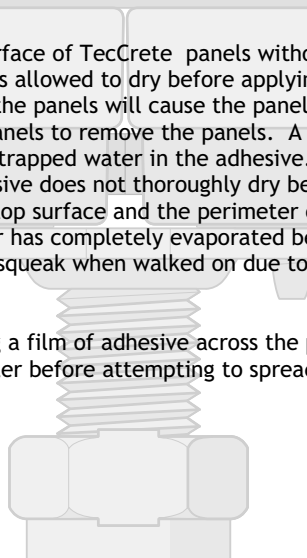

## 5. Sealing TecCrete

When TecCrete is being used bare without carpeting or any other covering Haworth recommends that the panel be sealed.

There are many concrete sealers on the market that will work with our TecCrete panels. Haworth does not specifically recommend any one brand of sealer over another. Here is a list of sealers Haworth Flooring Contractors have used with success.

Sealer Name	Manufacturer	Finish	Comments
<b>EUCO Diamond Hard</b>	<b>The Euclid Chemical Company 19218 Redwood Road Cleveland, OH 44110 800.321.7628 www.euclidchemical.com</b>	<b>High Gloss</b>	<b>High VOCs and strong odor when applied, but it gives the floor a nice sheen when dry</b>
<b>Super Aqua Cure VOX</b>	<b>The Euclid Chemical Company 19218 Redwood Road Cleveland, OH 44110 800.321.7628 www.euclidchemical.com</b>	<b>Mat Finish</b>	<b>Low VOCs and low odor</b>
<b>ECO Procote Soy Crete Concrete Stain</b>	<b>The Safety Products 1522 E. Victory St., Ste 2 Phoenix, AZ 85040-1307 877.366.7547 www.ecosafetyproducts.com</b>	<b>Colored Stains</b>	<b>Very low VOCs and very low odor, lots of colors</b>

Haworth is unaware of any chemical incompatibility between our access floor and these sealers, but due to the variability of site conditions and customer preferences the product should be tested on-site before applying the sealer to the entire floor.

Please note: to get the best results, it is important to follow the manufacturer's directions for whichever sealer you are using.

## 9 LATERAL BRACE KITS

### 9.1 Lateral Brace Kits

Lateral brace kits consist of two metal straps and a turnbuckle. They are used in any location where the floor must be restrained against lateral movement such as fascia conditions, steps, ramps, or equipment locations. Attach the brace to the subfloor with a mechanical anchor and then to the access floor panel as shown in [Figure 13](#). Tighten the turnbuckle by hand to secure the panel in place. Attach any fascia after the brace is installed. ( [See figure 13](#) )

Figure 13

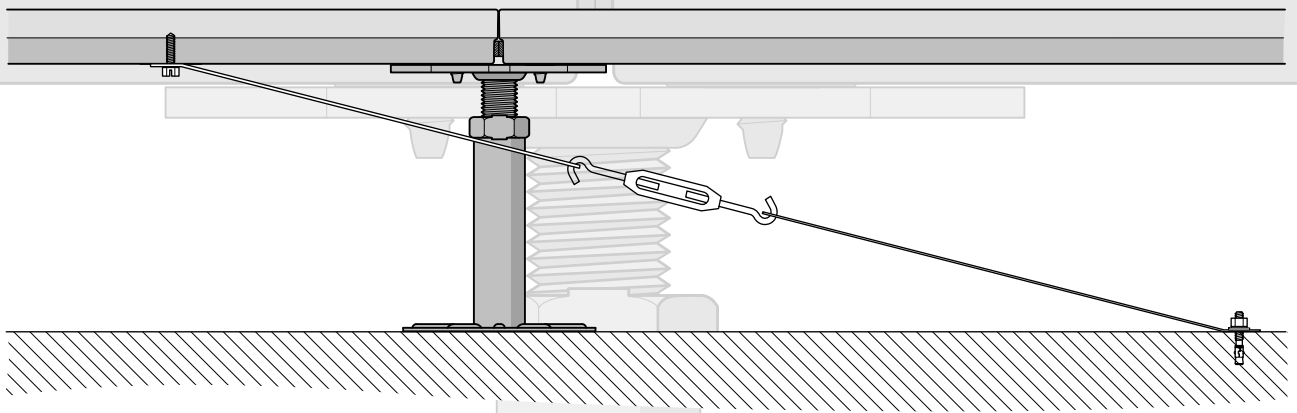

## 10 GROUNDING OF THE ACCESS FLOOR SYSTEM

Grounding of the access floor system is provided for three basic reasons: a) a drain path for static electricity; b) protection of people working in the access floor plenum against electrical shock; and c) to provide a reference grid for some high speed computer communication. Each of these reasons has different design requirements and the on-site Electrical Engineer should be consulted regarding these needs for any facility. Typically, the various grounding systems are installed by electrical contractors. A brief discussion of each of these elements is provided below.

### 10.1 Static Control

The principle element in static control is the selection of the floor covering on the access floor panels. Various levels of static control are required for different end uses. There are two methods for specifying static control in access floor systems; the surface to understructure resistance as tested by modifying NFPA 99 to locate the electrodes on the panel surface and pedestals, and secondly, the Kilovolt rating specified in AATCC-134.

Most access floor specifications use the modified NFPA 99 test procedure and call for a resistance range from  $5 \times 10^{10}$  ohms (IBM Resistance Specification) when measured from the panel surface to the understructure. This resistance range provides personal shock protection and a drain path for static charges to the understructure. This resistance range also reduces the sensible static discharges felt by personnel working in the area. High pressure laminates and EDS carpet finishes provide this range of surface to understructure resistance when measured by modified NFPA 99 test procedures. Thus, these finishes are suitable for most computer room and general office applications.

The NFPA 99 procedure is also specified in more critical areas such as clean rooms and electronic assembly areas with lower resistance values of  $2.5 \times 10^4$  to  $1 \times 10^6$  ohms. These applications require faster drainage and lower accumulation of static charges to prevent damage to exposed circuits. Access floors can conform to this specification by using conductive floor finishes applied with conductive adhesives to the access floor panels. If your application requires a panel to pedestal resistance is required to be less than 10 ohms.

Carpet tile specifications will typically use the AATCC-134 method to produce a maximum static accumulation rating for the carpet construction under the methods used in the test. A rating of 3 KV (kilovolts) is generally considered suitable for the general office by the carpet industry. This specification method may not mean a particular carpet construction is suitable for general office or computer room applications. Some carpets conforming to the 2.0 KV rating may be constructed of polyolefin fibers which are not acceptable for high wear application, nor do they provide a consistent path for draining static electricity.

Vinyl reinforced tiles do not conform to any of these specifications and are not suitable for most computer room or clean room applications from a static control viewpoint. If vinyl reinforced tile is specified with one of the above resistance specifications, an exception to the resistance range specification must be made.

Neither National Electrical Code nor Haworth require grounding of access floors used in office applications. In some computer room applications it is appropriate to attach the access floor components to a building ground which provides a complete path for the static drainage. Attach a #6 copper grounding wire to a pedestal at a minimum of once every 3000 sq ft and connect it to the building ground for this function.

### 10.2 Electrical Safety

The purpose of electrical safety grounding is to establish a path for accidental power connections to be forced to the building ground. This should cause a fuse to blow or a circuit breaker to disconnect. If this does not happen, the electrical circuit could remain "live" until a ground path is made. If the ground path is a person working on the floor or working in the floor plenum, they can establish a ground path by touching a conduit, water pipe, or building element and then receive a shock which could be life threatening. Interconnecting the access floor components with low resistance connections and attaching the access floor to the building ground should prevent this situation. Specifications will call for the resistance from the panel to understructure to be less than 10 ohms. To comply with this specification Haworth recommends using our grounding stringer screw to create a low resistance path from the panel to the understructure. Additionally, the access floor support system may be connected to the building ground by using a minimum #6 copper grounding wire in the following frequencies:

- Corner-Lock and Bolted Grid Systems: At a minimum of one connection point for every 3000 sq ft.
- Stringerless Non-Corner Lock Systems: At a minimum of one connection point for every 400 sq ft.

The exact size of the grounding conductor should be selected by the maximum voltage and amperage that is present in the floor plenum. Please refer to the National Electrical Code and your local electrical code requirements.

*Project specifications may have other requirements for grounding. Be sure you are complying with them.*

## 10.3 Reference Grids

Reference grids are used to interconnect high speed computer equipment to ensure that the data transfers are not affected by ground shift potentials between the two computers. They require complex connections and are typically constructed from 4" wide copper bands or heavy copper wires interconnected with welded or bolted connections. This system is placed beneath the access floor panels and is connected to the computer frames. The grid network is connected to a separate grounding bar isolated from the building ground. Alternatively, the access floor stringers may be used as a reference grid in some applications. Specifications typically call for the stringer to pedestal bonding resistance to be from 100 micro ohms to 100 milliohms.

If stringers are used as reference grids, you must:

- Clean, degrease, and brush the stringers surface and pedestal head where they meet. This removes any foreign matter and surface corrosion which could be on the parts.
- Apply conductive grease such as Thomas and Betts Copper Shield to the mating surfaces. The grease seals out moisture and air retarding oxidation at the joint between the pedestal head and stringer.
- Test your work in the field. Contact a reputable electrical testing laboratory for the specialized testing equipment needed to measure resistance this low.
- Clean and reapply the conductive grease if the joint is broken after installation.
- Inform the General Contractor of the completion of the installation and testing, and get their approval. Also advise them that subsequent disturbance of the stringer connections will require the cleaning and conductive grease to be reapplied and the connections tightened to a maximum 40 in-lbs of torque.

## 11 FASCIA APPLICATION & STEP DETAILS

### Fascia installation

Attach the bottom angle to the subfloor using pedestal adhesive. If installing fascia while the adhesive under the pedestal is wet; slide the leg of the angle under the pedestal base plate and secure the pedestal to the angle with adhesive. If you are installing the fascia after the adhesive has set cut the bottom angle to fit between the pedestal base plates.

Cutting the fascia plate to the proper height by holding the fascia against the bottom angle and the edge of the access floor. Mark a line by using the edge of the access floor as a guide. Cut the plate 1/8" shorter than the line so the cut fascia will come up to the bottom edge of the panel. Cut sections of top angle bracket and miter all corners. Drill and countersink holes in the top of the trim angle at 18" intervals. Attach the top angle to the access floor surface making sure to firmly secure the fascia plate against the panels. Note: The top angle bracket should be installed over the top of the floor covering.

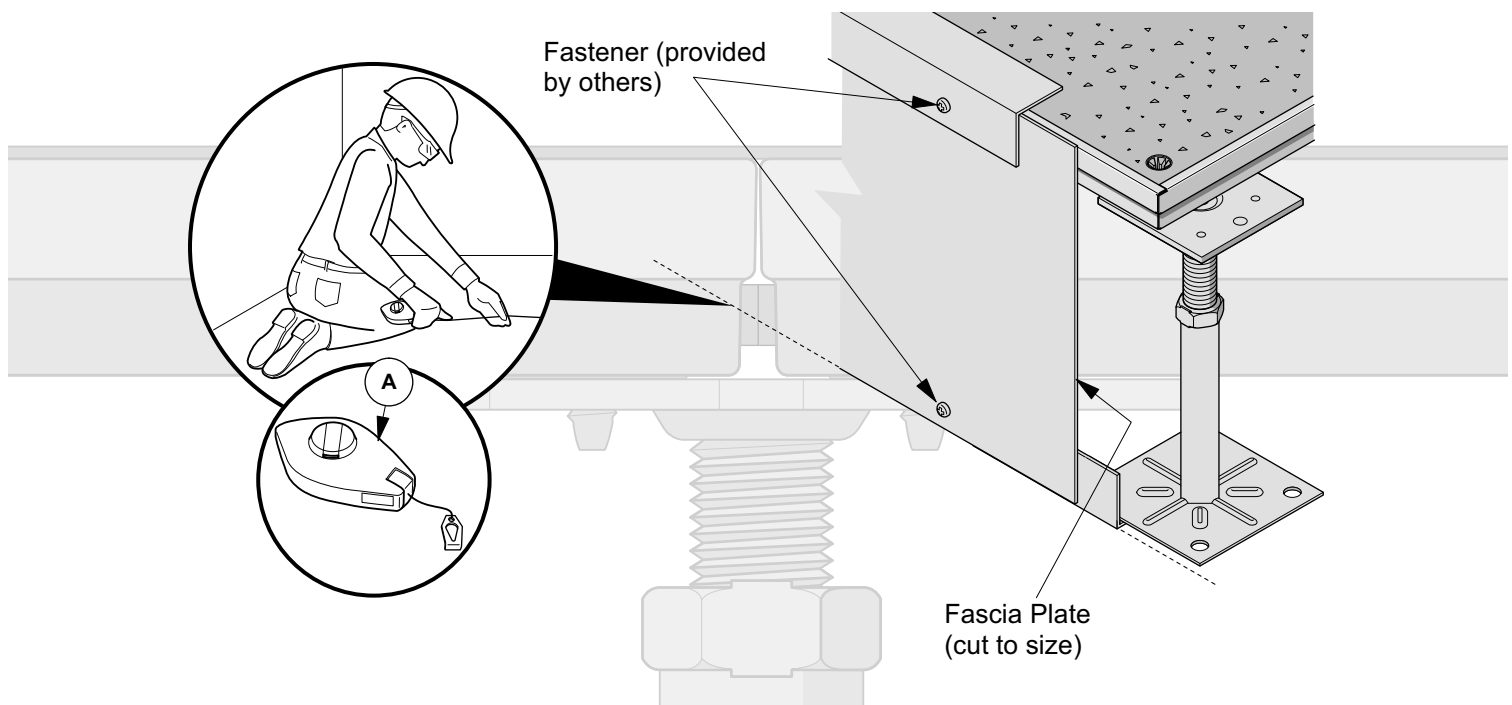

## 11.1 Step Installation

When building steps with access floor materials limit the overall height of the step assembly to three risers. Keep the width of the steps to 2 foot increments if possible to allow uncut panels to be used. Verify step tread and riser dimensions with local code officials. As a general guideline Use 12" deep and a riser height of 6". Cover steps with a non-slip floor covering.

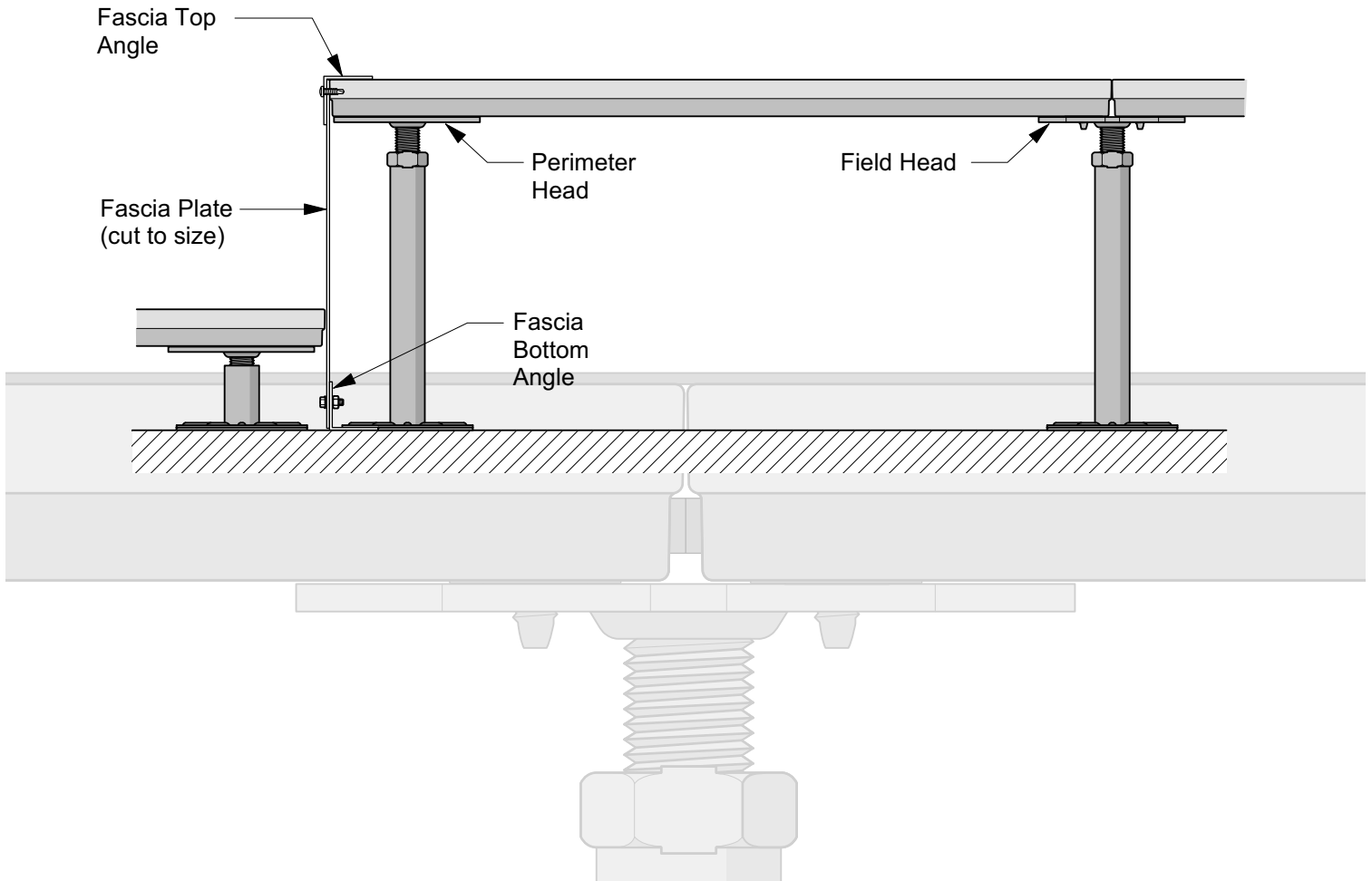
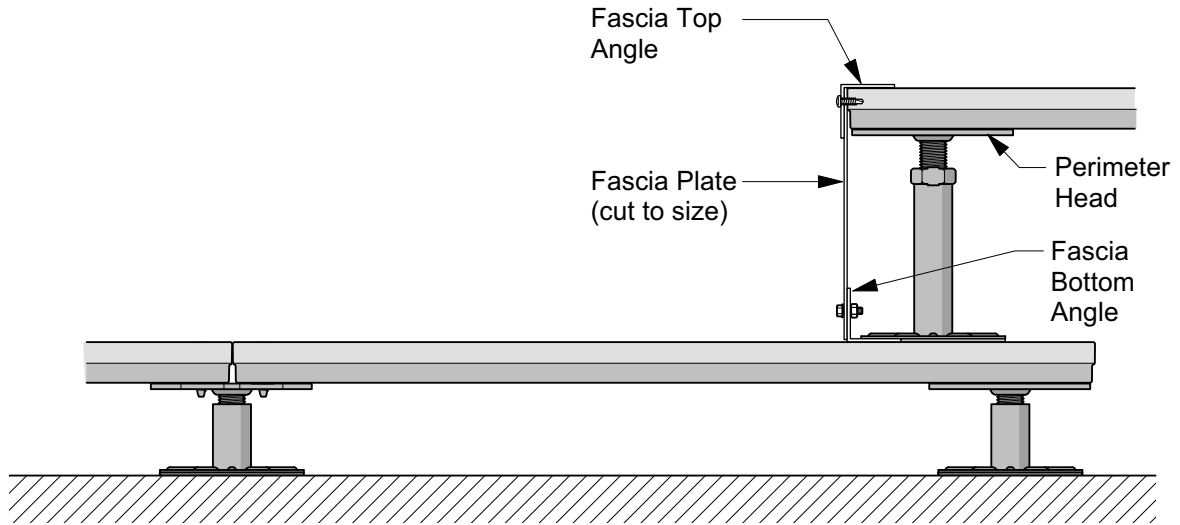

## 12 LEAKAGE

It is important to effectively prevent unintentional air leakage in a TecCrete access floor installation. Your general contractor should seal the building at the slab-line before the access flooring is installed. Irregular wall surfaces may require gaskets, caulking or tape to properly seal access floor to wall connections. It is also important that all utility access points be carefully sealed using plenum rated sealing material at all seams, spaces around pipes and columns.

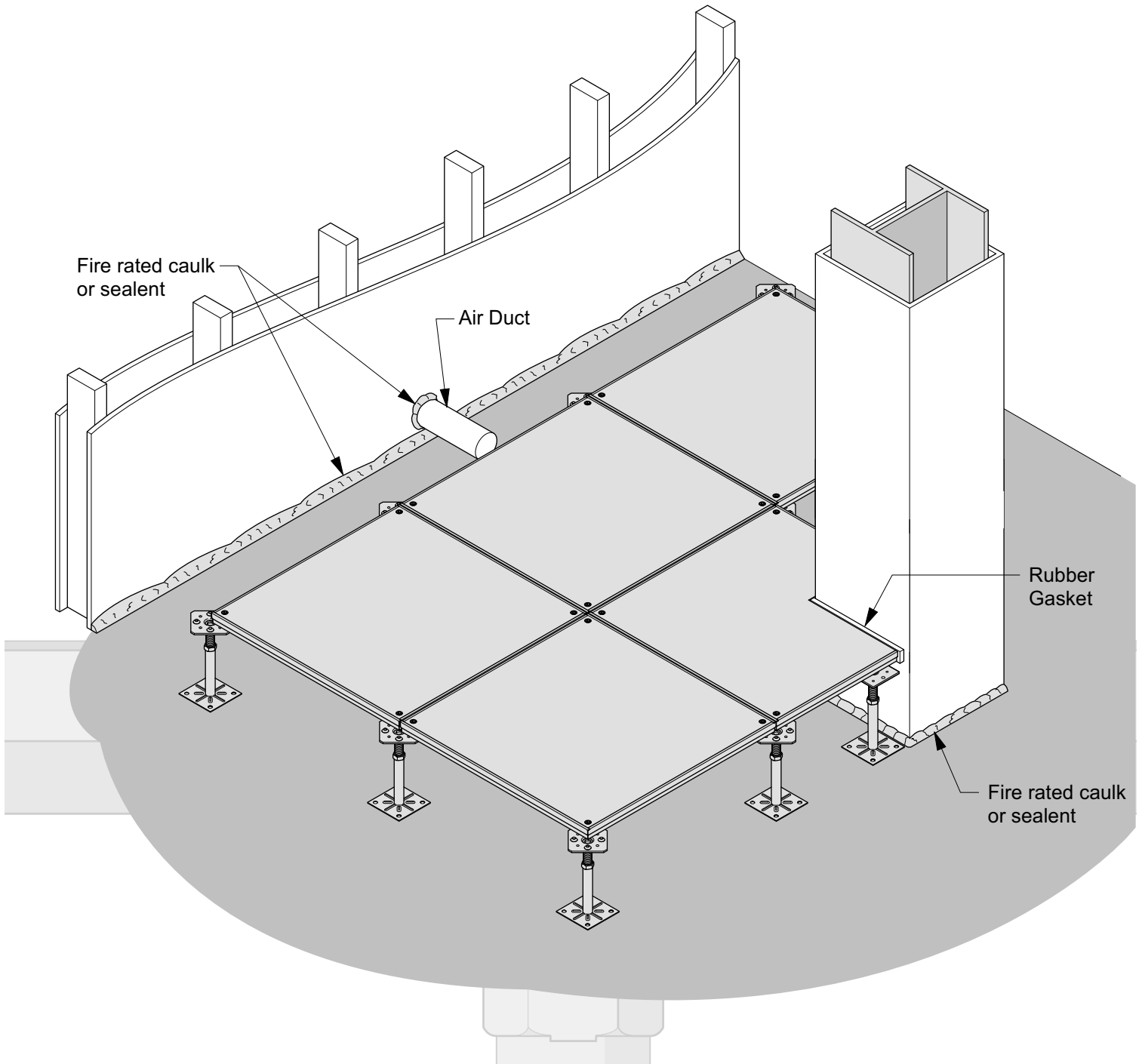

## Raised Access Flooring TecCrete: 1-1/8" and 1-1/2" Panel

- **Owner's Manual**

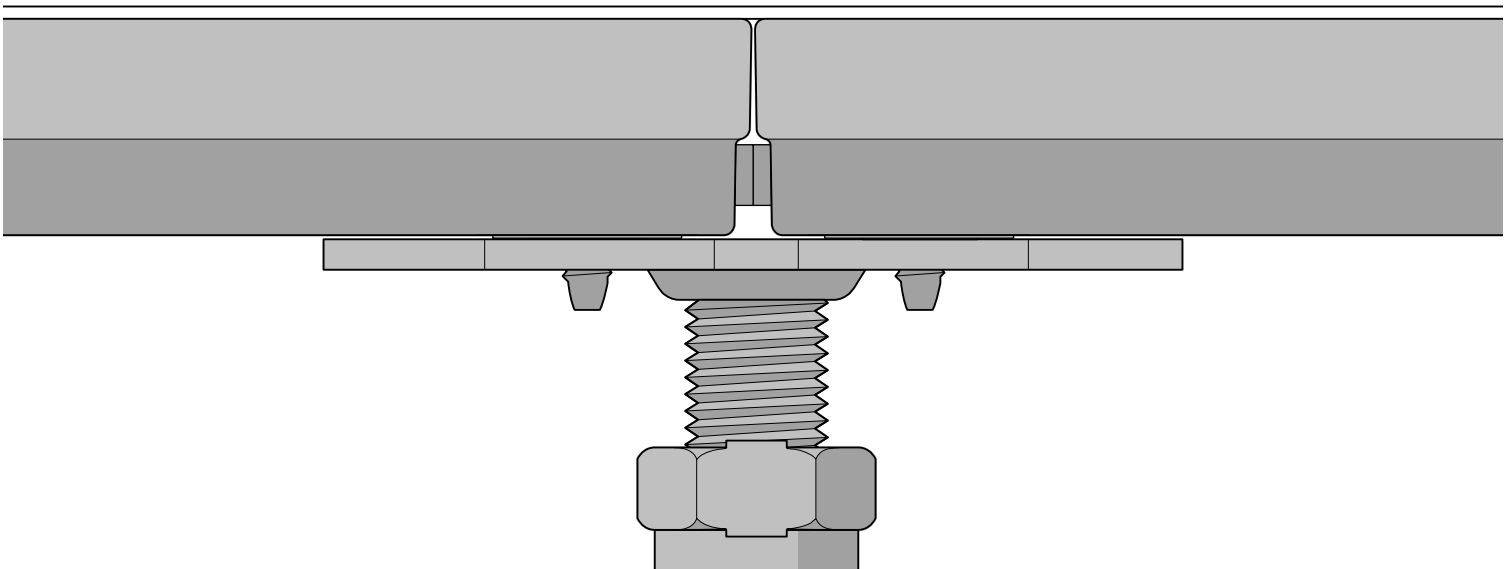

## 1 OWNERS MANUAL

Access flooring systems are considered to be interior finishes. The floor should always be protected from the elements and exterior weather conditions. The panels should always be stored or maintained on-site in a secure and dry environment. Areas should be maintained between 40 degrees F and 90 degrees F with a relative humidity range between 35% and 70%. The basic needs are as outlined below.

### 1.2 Removal and Replacement of Panels

- Use the appropriate lifting device to remove the panels from the floor. The devices will protect individuals and the access floor from injury or damage.

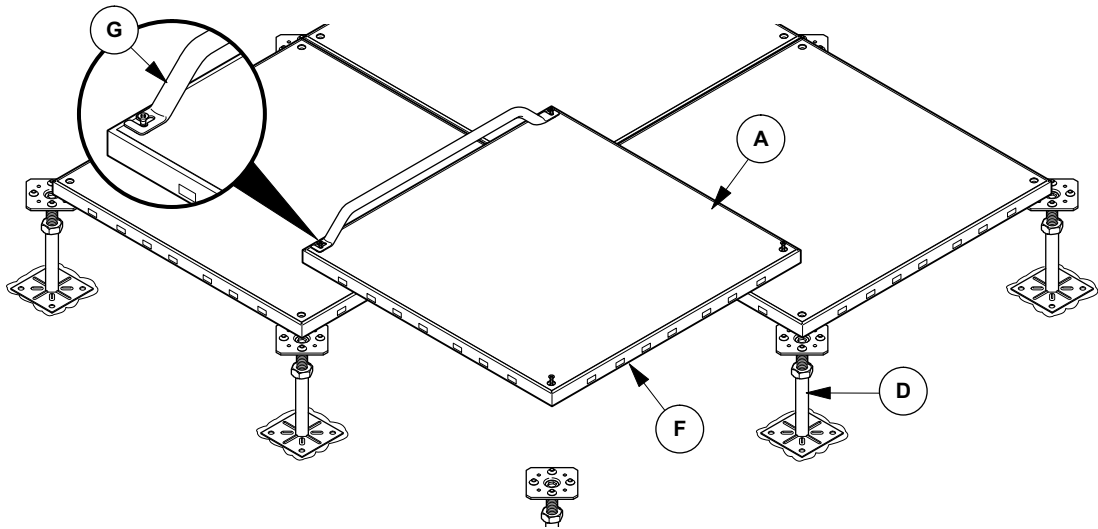

- Lift the panel clear of the floor system and lay the panel down top side up and out of the way. Remove the lifting device until ready to replace the panel. To replace the panels place the panel straight onto the pedestal head.
- When access to the cavity under the access floor system is required, only those panels directly over the area of work should be removed.
- Caution should be taken while the floor panels are out of the system not to disturb the adjustment and location of the pedestals nor to bend or break them.
- With a corner-lock system, where each panel is secured to pedestals with fasteners, you must disengage all four corner fasteners prior to removing the panels. Be sure when replacing corner-lock panels that all four fasteners are re-engaged and are securely fastened with all four fasteners flush or below the top of the panel.
- Do not kick the panels in place. Do not drop panels in place. Do not use screw drivers or other tools to remove panels or to pry them back in place.
- Do not force panels in place which do not want to go back smoothly into the system. If you have this situation, the panels are out of alignment. Inspect and readjust the adjoining panels to allow smoother reentry of all panels.
- Failure to adhere to these removal and replacement instructions may result in excessive gaps between panels. It may also cause general misalignment or damage resulting from dropped panels causing broken pedestals or damaged panel edge.

### 1.3 Cleaning of Access Floor Finishes

Access floor systems should be vacuumed periodically to remove any dirt or dust particles and to prevent debris from falling into the plenum or support structure. This is particularly important prior to removal of panels and before replacement. Dirt and dust on the pedestal heads can cause squeaking.

#### 1. Bare Sealed TecCrete

Sweep or vacuum floor thoroughly. Damp-mop with warm water and mild multipurpose ammoniated floor cleaner is recommended. When damp mopping clean a small area at a time, wringing the sponge out frequently. When damp mopping a large floor, change water frequently. Rinsing is important. Although detergent directions may say rinsing is unnecessary any detergent film left on a floor will attract dirt.

Do protect the floor from tracked in sand and chemicals by providing mats at entrances Frequent cleaning of high traffic areas near entrance/exit during winter months may be required.

Dont use wax seal it is not necessary if the floor has been properly sealed. Dont flood the floor with liquid, or use anything other than a damp mop. Large amounts of water can weaken adhesive. Dont use strong abrasives or scrapers to remove stains.

## 2. Laminate/Vinyl Cleaning

Sweep or vacuum floor thoroughly. Damp-mop with warm water and mild multipurpose ammoniated floor cleaner is recommended. When damp mopping clean a small area at a time, wringing the sponge out frequently. When damp mopping a large floor, change water frequently. Rinsing is important. Although detergent directions may say rinsing is unnecessary any detergent film left on a floor will attract dirt.

Do protect the floor from tracked in sand and chemicals by providing mats at entrances Frequent cleaning of high traffic areas near entrance/exit during winter months may be required.

Dont use wax seal it is not necessary if the floor has been properly sealed. Dont flood the floor with liquid, or use anything other than a damp mop. Large amounts of water can weaken adhesive. Dont use strong abrasives or scrapers to remove stains.

## 3. Carpet Finishes

The basic methods for cleaning and maintaining carpet on access floors are minimally different from those of any other carpet substrate. Vacuuming to remove dirt, spot cleaning for difficult areas, immediately picking up spills, and periodic deep cleaning as required for your use will minimize more serious problems. Listed below are the preferred methods for these operations on specific carpets for access floor panels.

### a. Carpet Tiles

- The application of carpet tile adhesive must be controlled to prevent problems in access floor installations. Excess adhesive which may penetrate the panel joints creates the following problems: 1) attaches panels to each other requiring the panels to be cut apart for removal, 2) cause squeaks due to dried adhesive between the panels, and 3) may cause the panels surface to oxidize if the adhesive is not dry before the carpet tiles are placed on the panels. Use a sprayable type adhesive to give a light coating on the panel surface or apply the adhesive with a roller which has been leveled off so that globs of adhesive are not deposited on the panel surface and at the module lines to avoid these problems.
- Follow the cleaning instructions below for spot cleaning and vacuuming.
- Vacuums in computer areas should be designed for minimal static accumulation and the filtration system should prevent airborne particles. Damage to computer equipment and disc drives may result from airborne particles.
- Dry foam or dry powders are the preferred methods of cleaning the carpet tile surface. Use minimal amounts of water to prevent water from entering into the plenum space. Excess water in the plenum area can cause electrical shorts and malfunctions. A second suctioning is desirable to remove excess water from carpet tiles.
- Do not use rotary brush cleaning. They may allow water into the plenum space and will require long periods to dry.
- Use a pile brush in high traffic areas prior to vacuuming and deep cleaning.
- Use chair mats at desks to prevent early wear.
- Rotate carpet tiles from high to low use areas to extend appearance and life of the carpet tiles.
- Steam and or hot water extraction can cause corrosion, delamination, and electrical hazards. If this method is used, do not allow excess cleaning materials to accumulate.

## 4. Carpet Maintenance Suggestions

### a. Entry Areas

Walk-off mats are the first line of defense in prolonging the life and appearance of carpet surfaces. They should be vacuumed daily for an 8-hour work day; two times daily for a 16-hour work day; and four times daily for an around-the-clock work day. These areas should also be deep cleaned according to the following schedule - once a week for an 8-hour or a 16-hour work day and twice a week for an around-the-clock work day.

## b. Vacuuming

Daily vacuuming is the most important part of the total carpet care program. Improper or ineffective vacuuming will accelerate wear and will allow dirt and grit to penetrate pile surfaces. All areas should be vacuumed with a dual motor vacuum with a three micron internal filtering system for cleaner air discharged. The vacuum should have an adjustable pile height head, brush wear attachment, and a top loading bag.

Vacuuming frequency will also depend on room area functions. Heavy and moderate traffic areas such as lobbies, entrances, interior traffic aisles should be vacuumed daily. Low traffic areas such as conference rooms, cubicles, and general office spaces should be vacuumed twice weekly.

## c. Spot Cleaning

Spots and stains are a detriment to the appearance level and should be promptly taken care of. Do the following on a daily basis:

- Pre-spray with a water based cleaning agent with a pH range of 8.5 to 9.5 and allow it to soak for 10 minutes.
- Agitate the soiled area with a soft-bristled nylon brush and extract the residue with warm water and a clean rag.
- Do not allow the pre-spray to dry prior to blotting up the stain as it will be ineffective once it is dried.
- Apply Interface Coffee Breaker to coffee stains. Do not blot up Coffee Breaker.

## d. Deep Cleaning

Use the dry foam or dry powder methods to minimize the water applied to the floor. Develop a schedule effective for your usage. Follow the instructions on the cleaning solutions label and on the cleaning equipment. As a minimum, the following frequencies are suggested:

- Heavy traffic areas such as lobbies, entrances, and traffic aisles should be done monthly.
- Moderate traffic areas such as interior traffic aisles and medium traffic aisles should be done quarterly.
- Low traffic areas such as conference rooms, cubicles, and general office areas should be done two times per year.

When using the dry foam method, it is recommended to double-extract the cleaning solution a second time without water or cleaner to make sure the excess water is removed from the carpet.

## 1.4 Recommended Tools List

- Bar lifter for bare TecCrete panels, Suction cups/carpet lifter
- Battery powered torque limiting screw gun, Black & Decker, Hitachi, or Mikita
- Replacement tips for the screw gun, #2 and #3 Phillips
- No. 2 and #3 Phillips screw drivers
- Vacuum cleaner
- Orbital bayonet saw with carbide grit blades, Milwaukee or Black & Decker Pro Orbital

## 1.5 Removal of Pedestal Adhesive from Subfloor

Removal of the pedestal adhesive from the subfloor can be hard to do. Once the adhesive has fully cured to the subfloor removal without damage to the concrete slab can be very labor intensified. We would suggest that the pedestal base plate be heated with a small blow torch or hot air gun to gently heat the surface of the base plate until the adhesive becomes plastic enough to allow the base to become unseated. At that point use mineral spirits or citrus based cleaning compounds to remove any left over adhesive on the subfloor.

## 2 WARRANTY PROCEDURE

In the event that a defect is found in Haworth Architectural Interiors products, which fall under our standard published warranty, such defects should be reported to Haworth Architectural Interiors in a timely manner. Haworth Architectural Interiors desire is to correct problems experienced in the field and to take any corrective action that may be dictated within our own manufacturing processes to prevent future occurrences.

1. Check the applicable warranty for your project.
2. When reporting defects to Haworth Architectural Interiors, the information needed to allow us to process the report is as follows:

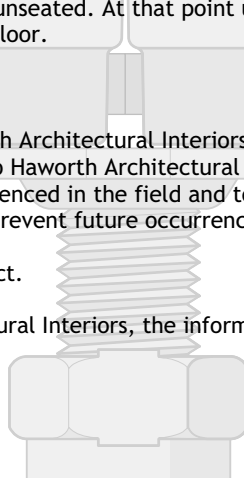

- Include the Haworth Architectural Interiors job number, which can be taken from the order acknowledgement and/or invoice and the date when the product was installed.
  - A description of the defect.
  - The scope of the problem such as quantity (or estimated quantity) of items exhibiting the defect. Depending on the scope of the problem, a field visit from a Haworth representative may be required.
  - Impact of the defect upon ongoing installation work and progress on the job.
3. Before incurring any expense in relation to taking field corrective action on the job, Haworth requires the submission of a written estimate of such costs for prior approval by Haworth Architectural Interiors.
  4. Haworth will not accept back charges for cleaning, corrective action, or extra work unless notified and agreed upon in writing prior to the performance of any such work.

END OF MANUAL

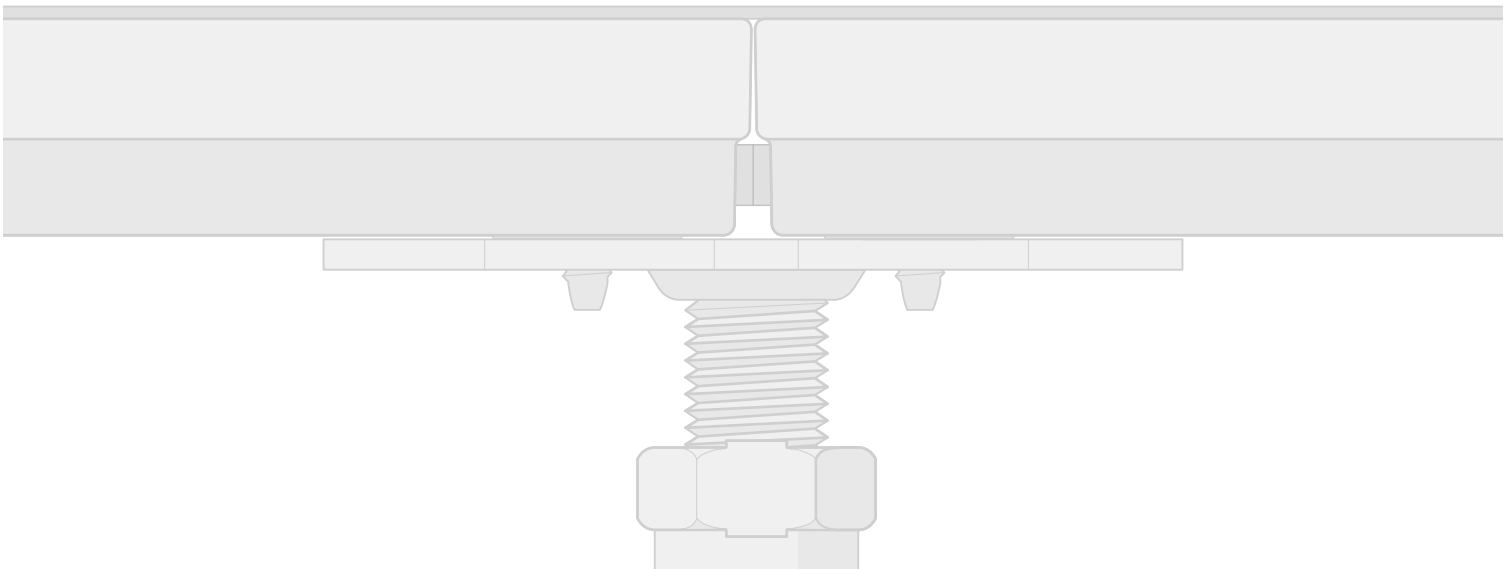

## Floor Product Warranty

(This Haworth Product Warranty applies to flooring products manufactured after January 1, 2006.)

If a new flooring product purchased or leased from Haworth, Inc., Haworth, Ltd. Or Haworth AI, LLC (each called "Haworth") or from an authorized Haworth dealer proves to be defective (as defined below) while the product is still owned by the initial purchaser or lessee and if the initial purchaser or lessee gives Haworth written notice of the defect within the Applicable Warranty Period, then Haworth will, at Haworths option, either repair or replace the product, at Haworths expense, or refund to the buyer the purchase price of the product. A notice must be addressed to Haworth at One Haworth Center, Holland, Michigan 49423, Attention: Corrections Department. A product shall be considered "defective" if Haworth finds that it is defective in materials or workmanship and if the defect materially impairs the value of the product to the buyer or lessee. Applicable Warranty Periods are set forth below. The Applicable Warranty Period for a flooring product begins when its installation is completed.

<u>PRODUCTS</u>	<u>APPLICABLE WARRANTY PERIOD</u>
All flooring products, including underfloor power, other than factory-applied surfaces . . . . .	Three Years
Factory-applied surfaces . . . . .	One Year

A product will not be considered to be defective, and Haworth will not repair, replace or refund its price if the product (1) is "customers own material" (i.e. materials specified by the buyer or lessee that is not a standard Haworth product offering), (2) is not installed and used as recommended in Haworths written planning, installation and user guides (3) has been otherwise misused or suffered abusive damage. A defect in materials or workmanship does not include (a) normal wear and tear, (b) damage caused by an Act of God or by transportation, reconfiguration or other movement of the product, (c) a product alteration made without Haworths express written authorization, (d) colorfastness, consistency of the surface finish or the matching of the color hue of any material applied to the surface of our flooring product.

EXCEPT AS STATED ABOVE, HAWORTH DOES NOT MAKE ANY WARRANTY AS TO ANY PRODUCT AND, IN PARTICULAR, DOES NOT MAKE ANY WARRANTY OF MERCHANTABILITY OR OF FITNESS FOR A PARTICULAR PURPOSE. Product repair or replacement or refund of the price, at Haworths option, in accordance with this warranty, is the buyers or lessees exclusive remedy for a product defect. Haworth shall not have tort liability with respect to a product, and Haworth shall not be liable for consequential, economic, indirect, special, punitive or incidental damages arising from a product defect.

October 20, 2005

### PROJECT REGISTRATION WHERE REQUESTED

Project Name: \_\_\_\_\_ Haworth Job No.: \_\_\_\_\_  
City & State: \_\_\_\_\_ Date Installation Completed: \_\_\_/\_\_\_/\_\_\_  
Dealer Name: \_\_\_\_\_  
Address: \_\_\_\_\_ Contact Name: \_\_\_\_\_  
City & State: \_\_\_\_\_ Phone Number: \_\_\_\_\_